

Automatic Transfer Switching Equipment

ATyS a M ≤ 63 A





CONTENTS

1. GENERAL SAFETY INSTRUCTIONS	4
2. INTRODUCTION	5
2.1. The ATyS family product range	5
2.1.1. Selection guide	7
3. QUICK START	8
4. ATYS a M VERSIONS	10
4.1. Product presentation	10
4.2. Specifications and advantages	10
4.3. Supply types	10
5. OPTIONAL ACCESSORIES	11
6. TECHNICAL DATA	12
7. ENVIRONMENTAL CONDITIONS	13
8. PRODUCT INSTALLATION	14
8.1. Recommended orientation	14
8.2. Dimensions	14
8.3. Back plate mounted	15
8.4. DIN rail mounted	15
9. INSTALLATION OF OPTIONAL ACCESSORIES	16
9.1. Optional modules	16
9.2. Auxilliary contacts	17
9.3. Bridging bars 4P	17
9.4. Terminal shrouds	18
10. CONNECTION OF THE POWER CIRCUITS	19
10.1. Ratings / cross-sections table of correspondence	19
10.2. Three phase without neutral network	20
11. CONNECTION OF CONTROL/COMMAND CIRCUITS	21
11.1. Terminal connectors designation	21
11.2. Auxiliary contact operating schedule	22
12. OPERATION	24
12.1. Presentation of the product interface	24
12.1.1. Product interface	24
12.1.2. Reset	26
12.2. Manual mode	26
12.3. Manual switching	27
12.4. Padlocking	27
12.5. Power ON	28
12.6. Automatic mode	28
12.6.1. Sealable Auto/Manual cover	28
12.7. Possible actions	29
12.8. Optional modules operation	31
12.8.1. RS485 communication module	31
12.8.2. Fire input module	31
12.8.3. GenSet output module	32
13. MAINTENANCE	33
14. TROUBLESHOOTING GUIDE	34

1. GENERAL SAFETY INSTRUCTIONS

- This manual provides instructions on safety, connections and operation of the ATyS M transfer switch manufactured by SOCOMEC.
- Whether the ATyS is sold as a loose product, as a spare, as an enclosed solution or as any other configuration, this device must always be installed and commissioned by qualified and experienced personnel, in line with the manufacturers recommendations, following good engineering practices and after having read and understood the details in the latest release of the relative product instruction manual.
- Maintenance on the product and any other associated equipment including but not limited to servicing operations must be performed by adequately trained and qualified personnel.
- Each product is shipped with a label or other form of marking including rating and other important specific product information. One must also refer to and respect markings on the product prior to installation and commissioning for values and limits specific to that product.
- Using the product outside the intended scope, outside SOCOMEC recommendations or outside the specified ratings and limits can cause personal injury and/or damage to equipment.
- This instruction manual must be made accessible so as to be easily available to anyone who may need to read it in relation with the ATyS.
- The ATyS meets the European Directives governing this type of product and includes CE marking on each product.
- No covers other than that for auto/manu on the ATyS should be opened (with or without voltage) as there may still be dangerous voltages inside the product such as those from external circuits.
- **Do not handle any control or power cables connected to the ATyS when voltage may be present on the product directly through the mains or indirectly through external circuits.**
- Voltages associated with this product may cause injury, electric shock, burns or death. Prior to carry out any maintenance or other work on live parts or other parts in the vicinity of exposed live parts, ensure that the switch including all control and associated circuits are de-energized.

	DANGER	RISK: Electric shock, burns, death
	WARNING	RISK: Possible personal injury
	CAUTION	RISK: Equipment damage

- As a minimum the ATyS aM comply with the following international standards:
 - IEC 60947-6-1
 - GB 14048-11
 - EN 60947-6-1

The information provided in this instruction manual is subject to change without notice, remains for general information only and is non-contractual.

2. INTRODUCTION

ATyS a M “Automatic Transfer Switching Equipment” (ATSE) is designed for use in power systems for the safe transfer of a load supply between a normal and an alternate source. The changeover is done in open transition and with minimum supply interruption during transfer ensuring full compliance with IEC 60947-6-1, GB/T 14048.11.

The ATyS a M is a full load break (switch type) derived transfer switching equipment where the main components are proven technology devices.



As a Class PC ATSE, the ATyS a M is capable of “making and withstanding short circuit currents” assigned, GB/T 14048.11, IEC 60947-6-1 and equivalent standards with utilization categories of up to AC33B.

ATyS a M transfer switches ensure:

- Power Control and Safety between a normal and an alternate source.
- A complete product delivered as a fully assembled and tested solution.
- HMI for information about source availability and product status.
- Integrated and robust switch disconnection.
- Window with clearly visible position indication I – 0 - II.
- An inherent failsafe mechanical interlock.
- Stable positions (I – 0 – II) non affected by typical vibration and shocks.
- Constant pressure on the contacts non affected by network voltage.
- Energy Efficient with virtually no consumption whilst on the normal, alternate or off positions.
- Extremely rugged, error free and built in padlocking facility.
- Straight forward installation with effective ergonomics.
- Removable handle for manual operation in case of emergency.
- Auxiliary contacts for switch positions I – 0 - II (optional).
- Ample accessories to suit specific requirements.
- Fully integrated and pre-set ATS controller.

2.1. The ATyS family product range

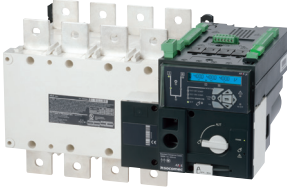
Just the right ATyS for your application...

ATyS: Small Footprint		ATyS M: Modular Profile	
<p>Back to Back Configuration</p>  <p>40A - 125A</p> <p>ATyS d S Small Genset with DPS</p> <p>ATyS S (RTSE) Small Gense</p>	 <p>125A - 3200A</p> <p>ATyS p Power/Genset Management</p> <p>ATyS g Simple Genset Management</p> <p>ATyS t Transformer Management</p> <p>ATyS d RTSE (DPS)</p> <p>ATyS r RTSE</p> <p>⁽¹⁾ATyS  RTSE</p>	 <p>40A - 160A</p> <p>ATyS p M Evolved Genset Management</p> <p>ATyS g M Simple Genset Management</p> <p>ATyS t M Transformer (building) Management</p> <p>ATyS a M Simple sources (building) Management</p> <p>ATyS d M RTSE (DPS)</p>	<p>Side by Side Configuration</p>

⁽¹⁾ The UL version of ATyS r is available from 100 - 400A

The ATyS M Range Key Features

Selecting the right ATyS M will depend on the application, the functionality required as well as the nature of the installation in which the ATyS M will be installed. Below is an outline product selection chart listing the key features of each product to help you select the right ATyS M for your needs.

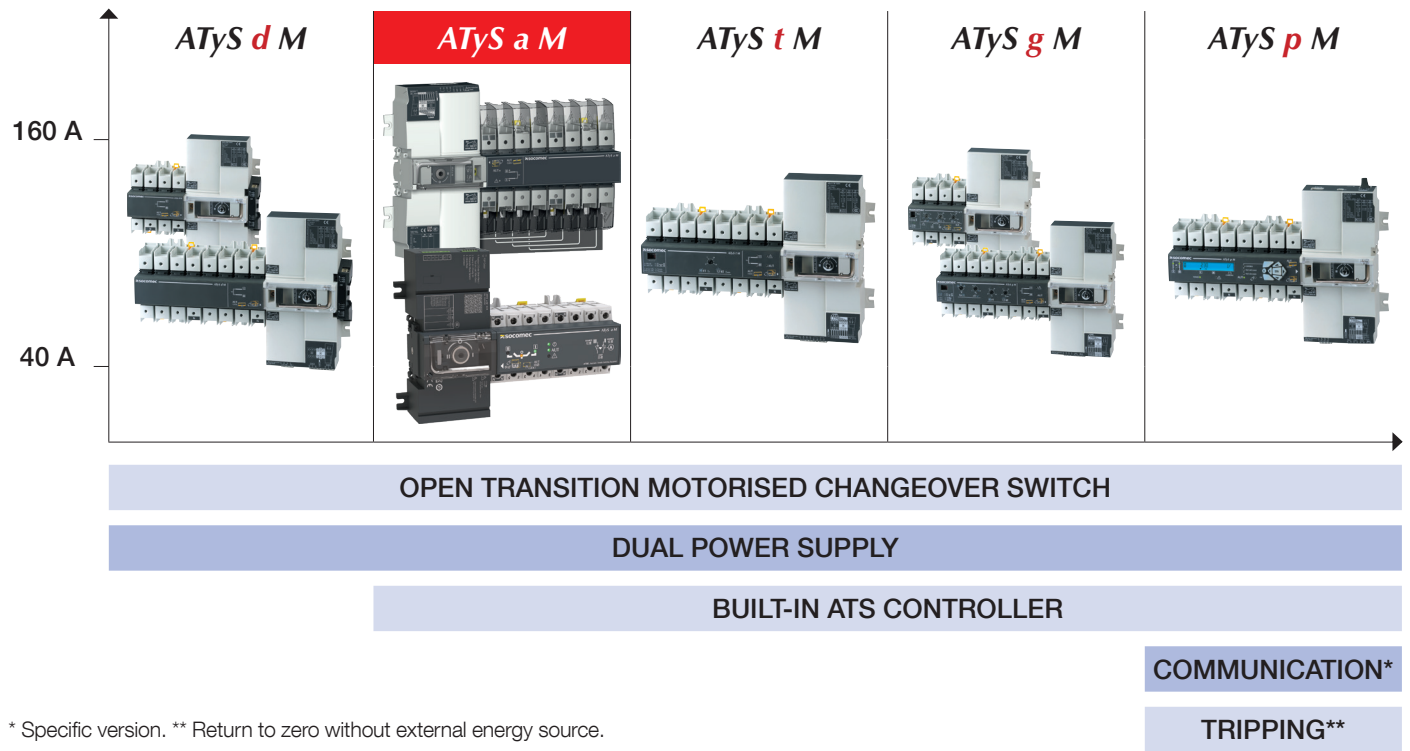

* Specific version. ** Return to zero without external energy source.

A product for virtually all power changeover applications from 25 to 160 A

- ▶ Network/Genset
 - ▶ Genset/Genset
 - ▶ Network/Network
- Applications with an External ATS Control

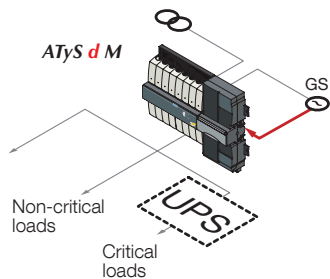

- ▶ Network/Network
- Building applications

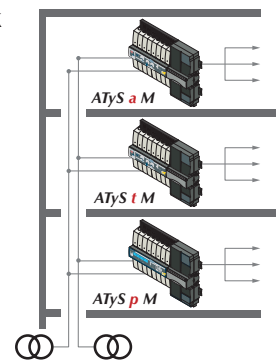

- ▶ Network/Genset
- Genset Applications for Standby Power

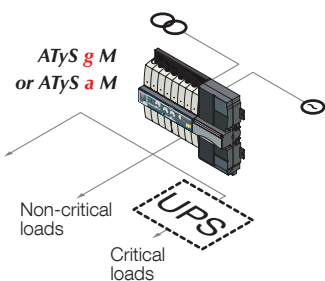

- ▶ Network/Genset
- ▶ Network/Network

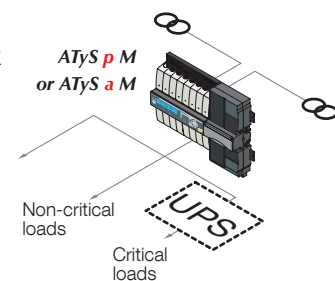

2.1.1. Selection guide

	<i>ATyS d M</i>	ATyS a M	<i>ATyS t M</i>	<i>ATyS g M</i>	<i>ATyS p M</i>
Applications					
Normal/Backup without automatic controller	•		•	•	•
Normal/Backup with built-in automatic controller		•	•	•	•
Stable positions	•	•	•	•	•
Load changeover	•				
FUNCTIONS					
Power supply					
External	•				
Integrated		•	•	•	•
Operation					
Backup manual operation of the 3 positions	•	•	•	•	•
Electrical (dry contact) control of positions I, 0 and II	•				•*
Automatic control of positions I, 0 and II		•	•	•	•
Return to 0 position feature upon loss of source					•
Monitoring					
3 voltages on networks I and II		•	•	•	•
Frequency on networks I and II		•	•	•	•
Phase rotation on networks I and II		•			•
Asymmetry of networks I and II					•
Automatic controller configuration					
By potentiometer and micro-switch			•	•	
By screen + keyboard					•
V _n , F _n , V threshold, F threshold		•	•	•	•
Driving with or without priority***		•	•	•	•
Adjustable operating timers		Via software	•	•	•
Control type (impulse or switch/contactor)	•				
Display					
Position, fully visualised breaking	•	•	•	•	•
LED: source status, automatic mode, fault LED		•	•	•	•
LED: switch positions, supply, tests, control					•
V, F, timers, number of operations, last event					•
Remote Control					
Outputs					
Generator start/stop order		Option		•	•
Product availability (not fault / not manual / not inhibited)		•		•	•*
Source available			•		•*
Programmable output (source, availability, fault)					•*
Inputs					
Test on load		•		•	•*
Retransfer		•		•	•*
Automatic mode inhibit		•	•	•	•*
Position 0 order		•***	•		•*
Priority		•	•	•	•
Other programmable inputs (test off-load, position control, etc.)					•*
Remote control					
Human/Machine Interface (D10 and D20)					•
RS485 communication (MODBUS)		Option			•**

* 3 inputs/3 outputs (programmable).

** Product reference is different: communication by RS485 connection (MODBUS) allows up to 31 ATyS M to be connected to a PC or a PLC over 1500 m.

*** Optional module for 24Vdc fire input available.

3. QUICK START

QUICK START GUIDE

EN

socomec
Innovative Power Solutions



552343A



Socomec Resource Center
To download, brochures, catalogues
and technical manuals

ATyS a M

25 A - 63 A

Automatic Transfer Switching Equipment

Preliminary operations

Check the following upon delivery and after removal of the packaging:

- Packaging and contents are in good condition.
- The product reference corresponds to the order.
- Contents should include:
 - Qty 1 x ATyS a M
 - Qty 1 x Set of terminals
 - Quick Start instruction sheet



Warning

⚠ Risk of electrocution, burns or injury to persons and / or damage to equipment. This Quick Start is intended for personnel trained in the installation and commissioning of this product. For further details refer to the product instruction manual available on the SOCOMECE website.

- This product must always be installed and commissioned by qualified and approved personnel.
- Maintenance and servicing operations should be performed by trained and authorized personnel.
- Do not handle any control or power cables connected to the product when voltage may be, or may become present on the product, directly through the mains or indirectly through external circuits.
- Always use an appropriate voltage detection device to confirm the absence of voltage.
- Ensure that no metal objects are allowed to fall in the cabinet (risk of electrical arcing).

Failure to observe good engineering practices as well as to follow these safety instructions may expose the user and others to serious injury or death.

⚠ Risk of damaging the device
In case the product is dropped or damaged in any way it is recommended to replace the complete product.
Installation standards must be respected.

Accessories

- Bridging bars.
- Terminal shrouds.
- Auxilliary contact blocks.
- Optional modules.

1 Installation

⚠ Caution: Ensure that the product is installed on a flat rigid surface.

Dimensions (mm)

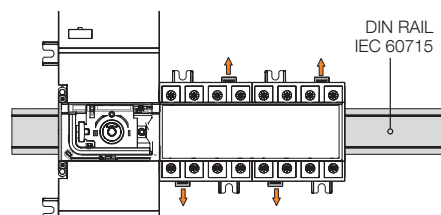
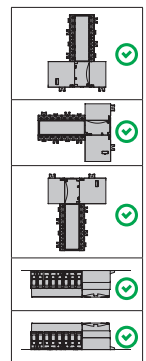
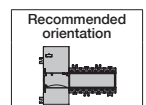
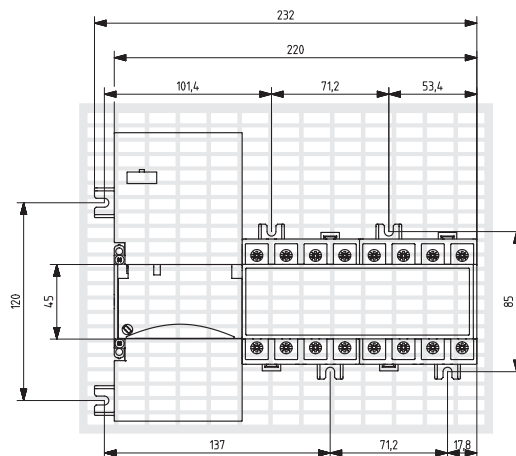
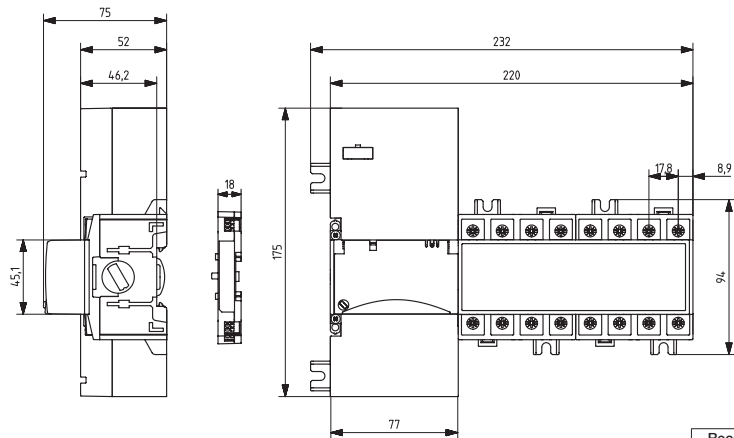

⚠ Tighten to avoid movement on the DIN rail.

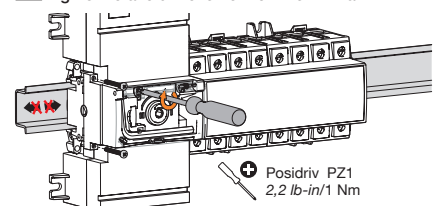

2 Power Terminal Connections

⚠ It is essential to tighten all used terminals, with cables and/or bridging bars, before use. Load side bridging bar : 20 - 63 A ref.: 9324 0001.

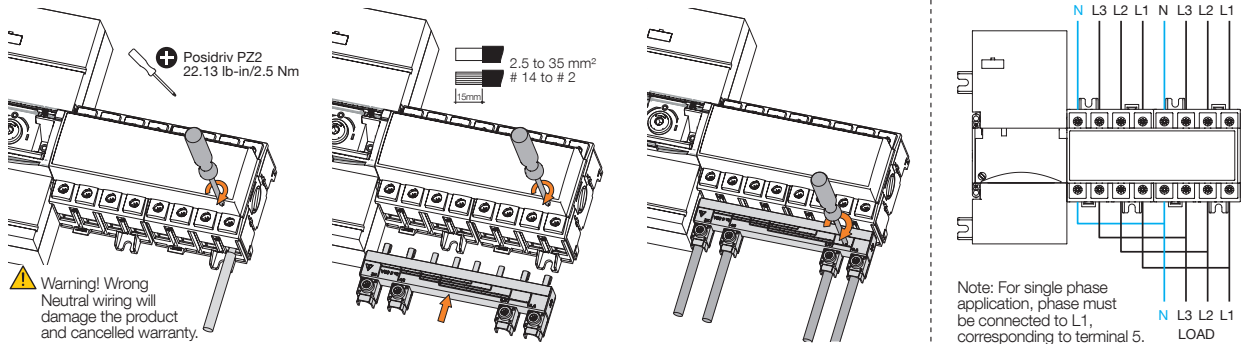

3 CONTROL / AUX POWER Terminals and wiring

Type	Terminal no.	Description	Characteristics	Recommended connection cross-section
Inputs	1	Position 0 order (Main-Main) Test on load (Main-GenSet)	Dry potential free contact	0,5 to 1,5mm ² (rigid & stranded)
	2	Priority S1 / Priority S2		
	3	Retransfer mode selector		
	4	Inhibition mode		
	5	Common		
Outputs	11/12	Product operational POP output	External 24Vdc±10% 20mAdc max	
Fire input optional module	-	24Vdc fire input signal	8.6 - 28Vdc	
GenSet output optional module	-	GenSet start and stop management	NC - 230Vac/3A	
RS485 optional module	-	Modbus RTU communication	Non isolated	0.5 to 1.5 mm ² - LiYCY cables
Auxiliary contacts unit.	11/12/14	Position I	Dry potential free contact 250Vac 5A AC1 24Vdc 2A	0.5 to 2.5 mm ² (rigid) 0.5 to 1.5 mm ² (stranded)
	21/22/24	Position II		
	01/02/04	Position 0		



Ensure that the product is in Manual Mode (front cover open).

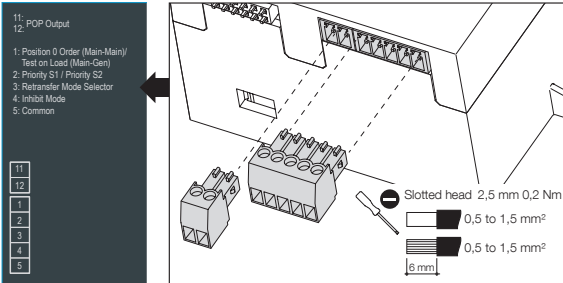

Auxiliary contacts: Fitting of auxiliary contacts: 1309 1001

To fit an auxiliary contact, the switch must first be put in position 0. An auxiliary contact module comprises one NO/NC changeover contact for each position (I-0-II). To install use the long screws supplied with the module.

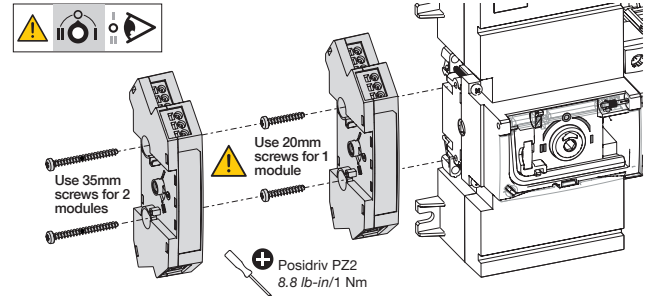

4 Check

Whilst in manual mode, check the wiring and if ok power up the product.



6A Automatic operation

Close the front cover as shown to put the product into automatic mode.



6C Padlocking mode

In order to padlock put the product in manual mode.



Pull the locking mechanism and insert a padlock as shown.

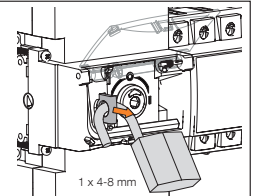

5 Programming

Programming settings on ATyS a M have been set.

Product is configured for 3 phase + neutral 380Vac network.

Neutral for both sources will be placed on the left as indicated on the ATSE device.

Thresholds:

- Voltage: +/-20%, hysteresis +/-15%

- Frequency: +/-10%

Source 1 has been set as priority source.

Fail timer as well as Return timer has been set to two seconds, for both sources.

6B Manual operation

Open the front cover as shown to put into manual mode.



Use the handle situated in the front panel under the cover to operate the transfer switch.
Check the changeover switch position on the indicator before operating.

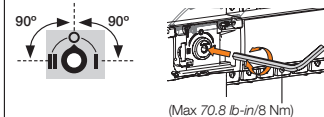

6D Source availability LED's

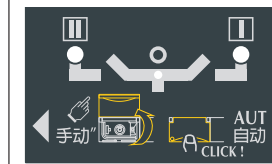

SOURCE	☐	☐
LED ON	Source 2 available	Source 1 available
LED OFF	Source 2 not available	Source 1 not available
LED blinking	Voltage presence but out of tolerance	



4. ATyS a M VERSIONS

The ATyS a M is available as 4P with the possibility of being used on virtually any automatic open transition type of application.

Measurement accuracy: Frequency: +/- 0,3Hz - Voltage: +/- 2%

4.1. Product presentation

This quick-acting transfer switch incorporates:

1. 2 mechanically interlocked switches.
2. A quick-acting electric control unit enabling automatic or manual system operation.
3. Electrical specifications compliant with product standards, and a version identification.
4. Changeover switch and sources informations.
5. Connection of control/command circuits.



CAUTION! If the product is mounted upside down (allowed), use the second supplied sticker to allow a good reading of product information.

4.2. Specifications and advantages



- 1 - Power section:
A fully integrated and interlocked transfer switch, with high electrical performance offering microprocessor control and monitoring.
- 2 - Operation:
A flexible operating mechanism enabling quick motorised transfer in automatic mode or locally in manual mode for emergency operations. Features a locking device to ensure (in position zero) a secured isolation of the load (padlocked).

4.3. Supply types

The power supply of ATyS a M control is required to be 220 VAC -20% to 220 VAC +20% at a frequency of 50/60 Hz and has been developed so as to meet most network configurations. Control supplied is taken between Phase 1 and Neutral, corresponding to terminal 5 and N terminal.

	Version 230 / 400 VAC	
	Umin	Umax
Ph-N	176	264
Ph-Ph	305	456

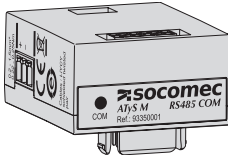
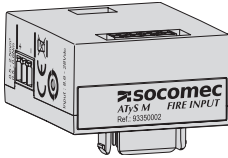
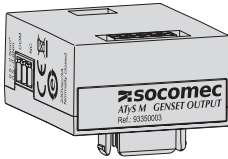
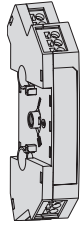
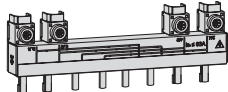
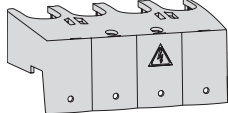
5. OPTIONAL ACCESSORIES

RS485 optional module	Plug-in module for Modbus RTU communication through RS485.		Ref. : 9335 0001
Fire input optional module	Plug-in module for fire signal (24Vdc) interpretation. When fire linkage is active, the transfer is inhibited and switch go to center OFF position for safety.		Ref. : 9335 0002
GenSet output optional module	Plug-in module for Generating Set start and stop management.		Ref. : 9335 0003
Auxiliary contacts	Each product can take up to 2 auxiliary contact blocks. Each accessory integrates 1 NO /N C auxiliary contact (for each position I, O and II) 1309 1001 for separated common points. Characteristics: 250 VAC / 5 A maximum.		Ref. : 1309 1001
Bridging bars	To provide a common point on the outgoing side of the switch (load side).		Ref. : 9324 0001
Terminal shrouds	Protection against direct contacts with terminals or connecting parts. Other features: Perforations allowing remote thermographic inspection without removal. Possibility of sealing.		Ref. : 9324 0002 2 parts/ref.
Auto-transformer	For use with ATyS M in 400 VAC three-phase applications without a distributed neutral. As the ATyS M has integrated measurement and power supply circuits, a neutral connection is required for 400 VAC three-phase applications. When no neutral connection is available this autotransformer (400/230 VAC, 400 VA) provides the 230 VAC required for the ATyS M to function.		Ref. : 1599 4121

6. TECHNICAL DATA

	Frame 63 A			
Thermal current I_{th} at 40°C	25A	32A	40A	63A
Rated insulation voltage U _i (V) (power circuit)	800	800	800	800
Rated impulse withstand voltage U _{imp} (kV) (power circuit)	6	6	6	6
Rated insulation voltage U _i (V) (control circuit)	450	450	450	450
Rated impulse withstand voltage U _{imp} (kV) (control circuit)	6	6	6	6
Rated operational currents I_e				
Rated voltage	Utilisation category (1)	A / B	A / B	A / B
415Vac	AC-31 A / AC-31 B	25/25	32/32	40/40
415Vac	AC-32 A / AC-32 B	25/25	32/32	40/40
415Vac	AC-33 iA / AC-33 iB	25/25	32/32	40/40
415Vac	AC-33 A / AC-33 B	-/25	-/32	-/40
Current rated as conditional short-circuit with fuse gG				
Conditional short-circuit current (kA rms)	50	50	50	50
Associated fuse rating (A)	gG fuse (A)	25	32	40
Current rated as conditional short-circuit with any brand of circuit breaker that ensures tripping in less than 30ms (2)				
Current rated as short-time withstand I _{cw} 30ms (kA rms)	5	5	5	5
Short-circuit operation				
Rated peak withstand current I _p (kA peak)	7.1	7.1	7.1	7.1
Connection				
Minimum Cu cable cross-section (mm ²)	2.5	2.5	2.5	2.5
Maximum Cu cable cross-section (mm ²)	35	35	35	35
Tightening torque (Nm)	2.5	2.5	2.5	2.5
Switching time (3)				
I - 0 or II - 0, following a command (ms)	80	80	80	80
Transfer time I - II or II - I, following a command (ms)	220	220	220	220
I-II or II-I transfer time, after outage (s)	2.2	2.2	2.2	2.2
Contact transfer time ("black-out") I-II min. (ms)	140	140	140	140
Power supply				
Min./max. auxiliary power supply (VAC)	176-264	176-264	176-264	176-264
Control supply power demand				
Rated power (VA)	2	2	2	2
Max. intensity at 230 VAC (A)	17.7	17.7	17.7	17.7
Mechanical specifications				
Durability (number of operating cycles)	10 000	10 000	10 000	10 000
Weight - non-packaged (kg)	1.8	1.8	1.8	1.8
Weight - including packaging (kg)	2.3	2.3	2.3	2.3

(1) Category with index A = frequent operation / Category with index B = infrequent operation.

(2) Value for coordination with any circuit breaker that ensures tripping in less than 30ms.

For coordination with specific circuit-breaker references, higher short-circuit current values are available. Please contact us.

(3) At rated voltage - excluding time delays, where applicable.

7. ENVIRONMENTAL CONDITIONS



Humidity

- 80 % humidity without condensation at 55 °C
- 95 % humidity without condensation at 40 °C



Temperature

- -20 +40 °C without de-rating
- 40 °C < t ≤ 70 °C with de-rating (see Technical Characteristics)



Altitude

- Up to 2000m without derating

Correction factors:

	2 000 m < A ≤ 3 000 m	3 000 m < A ≤ 4 000 m
Ue	0.95	0.80
Ie	0.85	0.85



Storage

- 1 year maximum
- Maximum storage temperature: +55 °C
- 80 % humidity without condensation at 55 °C



IP rating

- IP2x minimim for modular integration or with required door cut-out (222x47mm)

Protection class: Class 1

8. PRODUCT INSTALLATION

8.1. Recommended orientation

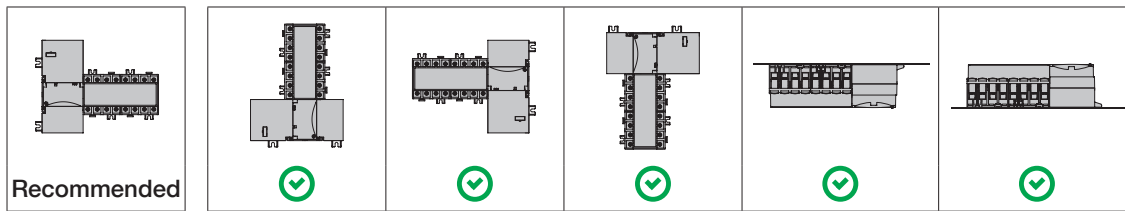

8.2. Dimensions

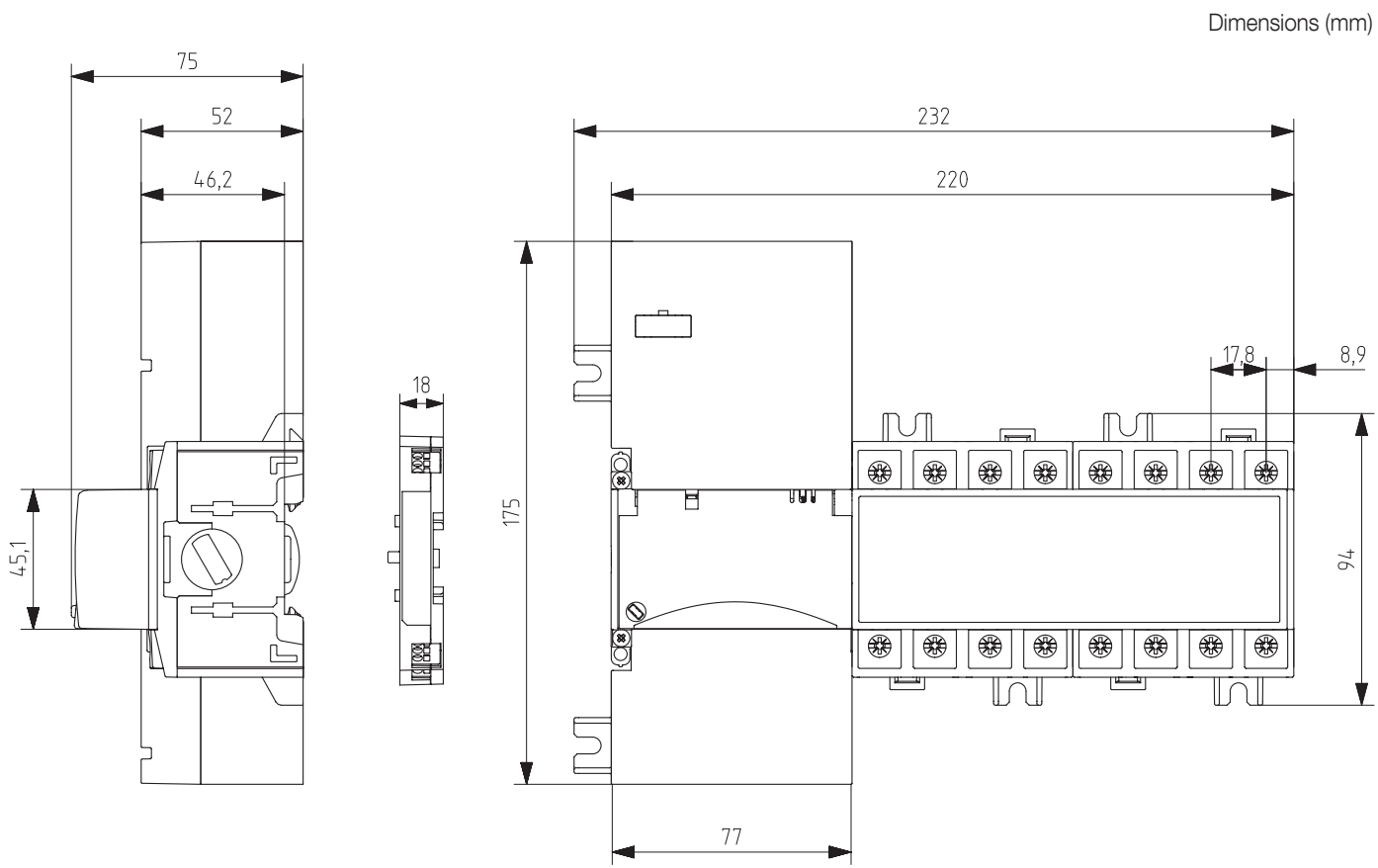

8.3. Back plate mounted

Dimensions (mm)

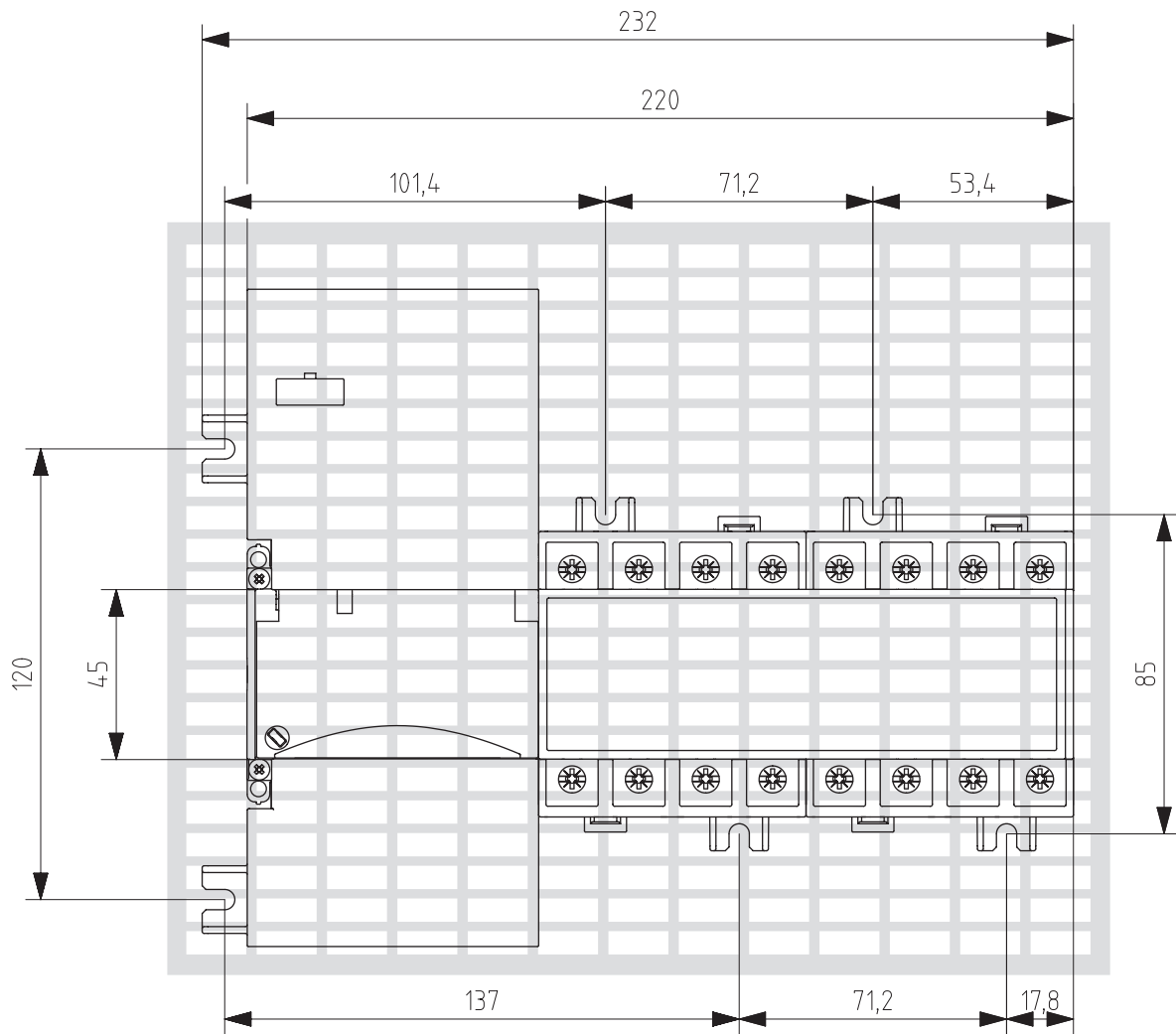

8.4. DIN rail mounted

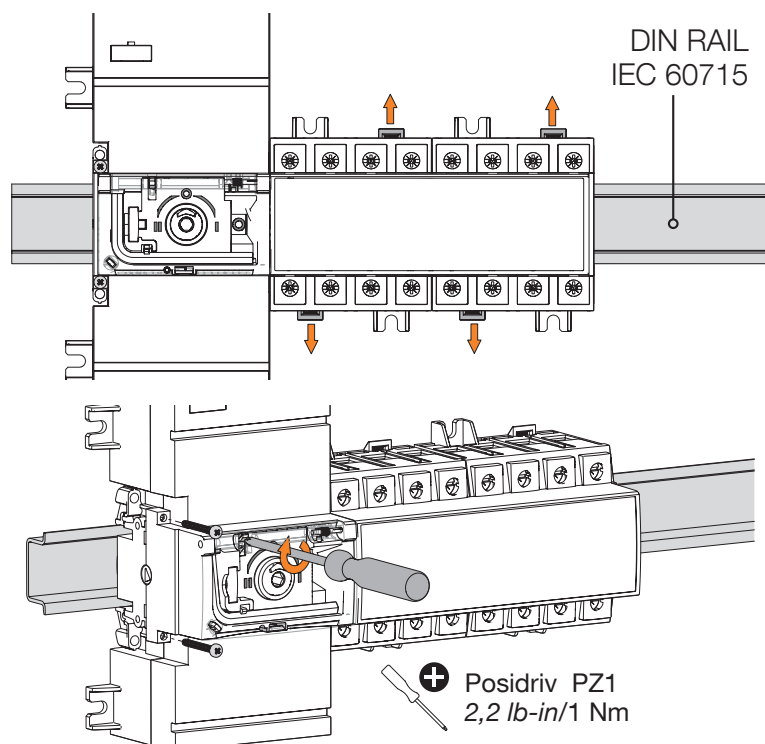

9. INSTALLATION OF OPTIONAL ACCESSORIES

9.1. Optional modules

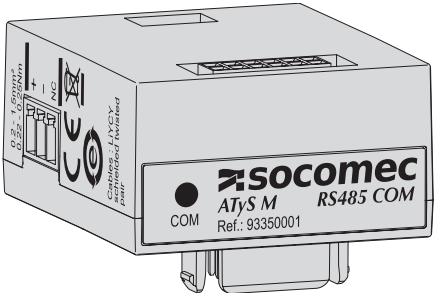
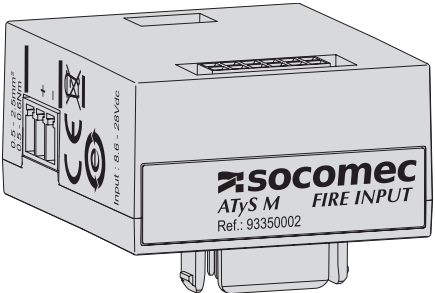
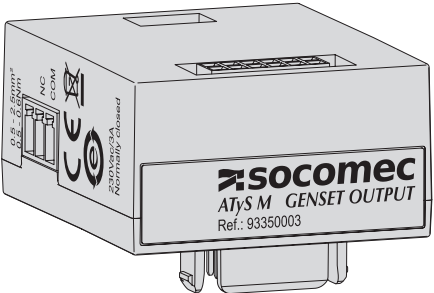
 <p>0,5 - 1,5mm² 0,5 - 0,6Nm CE Cables: LiYCY pair shielded twisted COM socomec ATyS M RS485 COM Ref.: 93350001</p>	 <p>0,5 - 1,5mm² 0,5 - 0,6Nm CE Input: 8,6 - 28Vdc socomec ATyS M FIRE INPUT Ref.: 93350002</p>	 <p>0,5 - 1,5mm² 0,5 - 0,6Nm CE COM socomec ATyS M GENSET OUTPUT Ref.: 93350003</p>
<p>RS485 communication module connection:</p> <ul style="list-style-type: none"> - Cables: LiYCY shielded twisted pair - Cross section: 0,5mm² - 1,5mm² - Tightening torque: 0,22Nm - 0,25Nm - H x W x L (mm) = 22 x 38 x 45 	<p>Fire input module connection:</p> <ul style="list-style-type: none"> - Cross section: 0,5mm² - 1,5mm² - Tightening torque: 0,5Nm - 0,6Nm - H x W x L (mm) = 22 x 38 x 45 <p>Input voltage: 8,6Vdc - 28Vdc</p>	<p>GenSet output module connection:</p> <ul style="list-style-type: none"> - Cross section: 0,5mm² - 1,5mm² - Tightening torque: 0,5Nm - 0,6Nm - H x W x L (mm) = 22 x 38 x 45 <p>Output signal: 230Vac / 3A Normally closed (NC) contact</p>

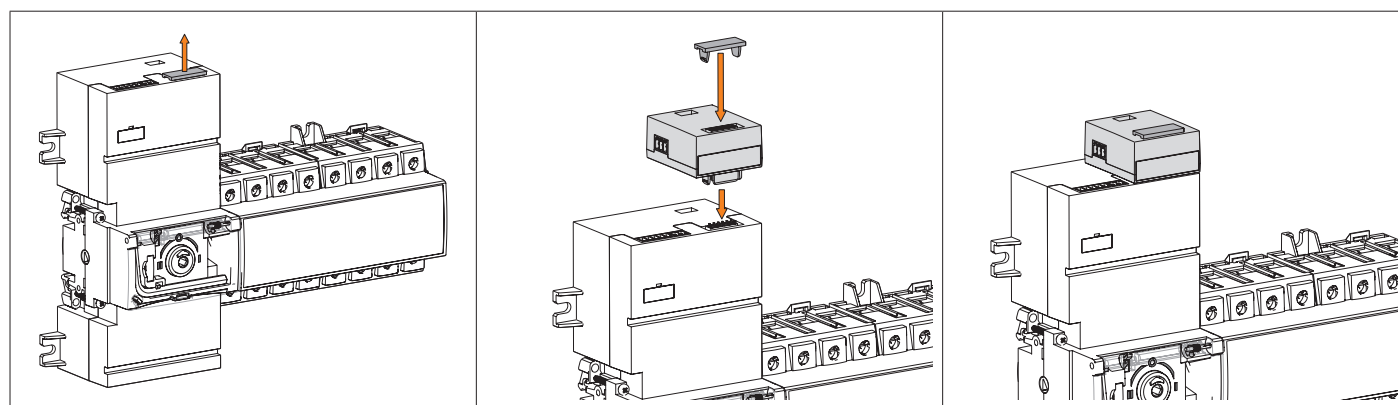

Remove the protection from the ATyS a M connector, before optional module installation. The same protection must be placed on the optional module female connector, if not used.

9.2. Auxilliary contacts

Ref. 1309 1001.

To fit an auxiliary contact, the switch must first be put in the 0 position. An auxiliary contact module comprises: one NO/NC changeover contact for each position (I-0-II). To install use the screws supplied with the module.

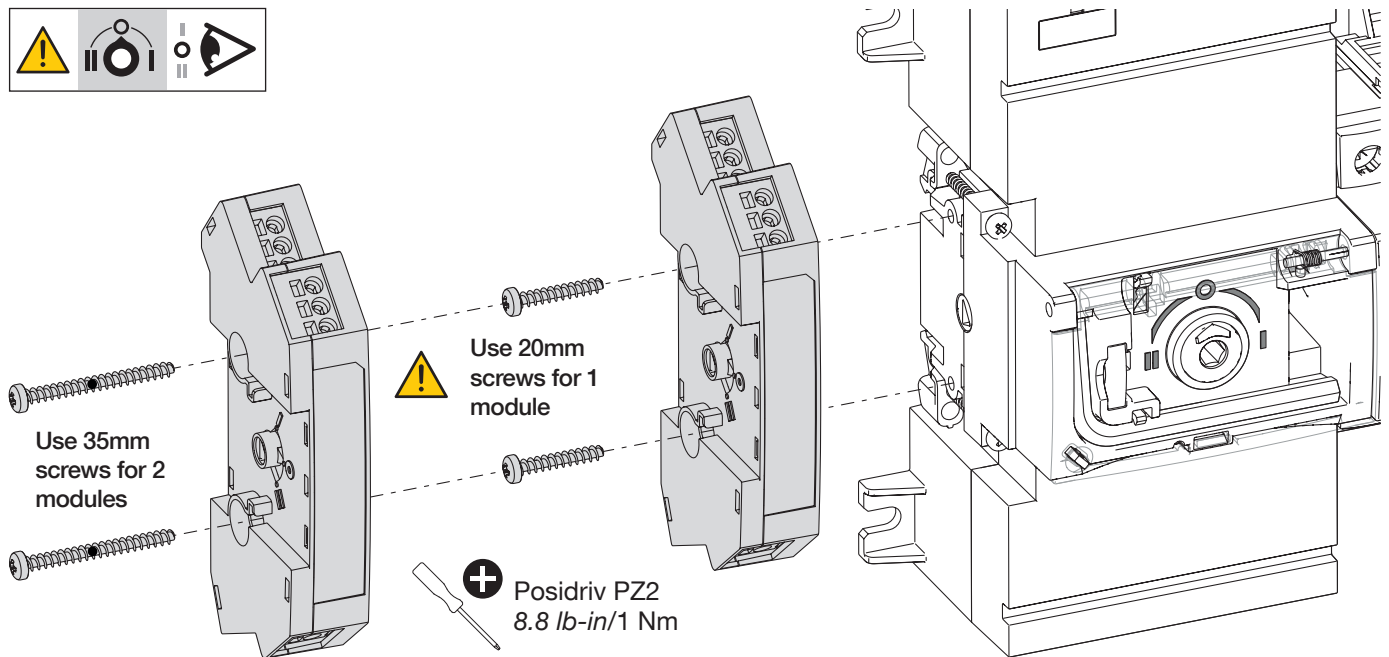

9.3. Bridging bars 4P

Ratings ≤ 63 A: ref. 9324 0001.



It is essential to tighten all used terminals, with cables and/or bridging bars, before use.

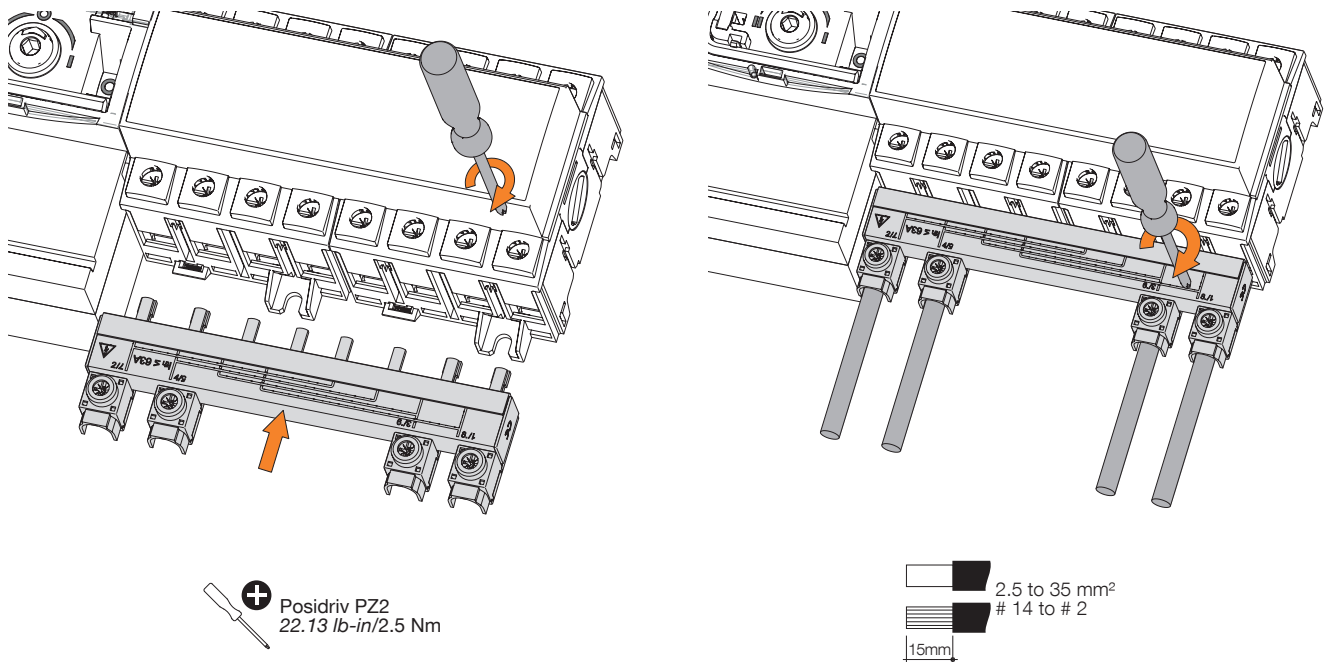

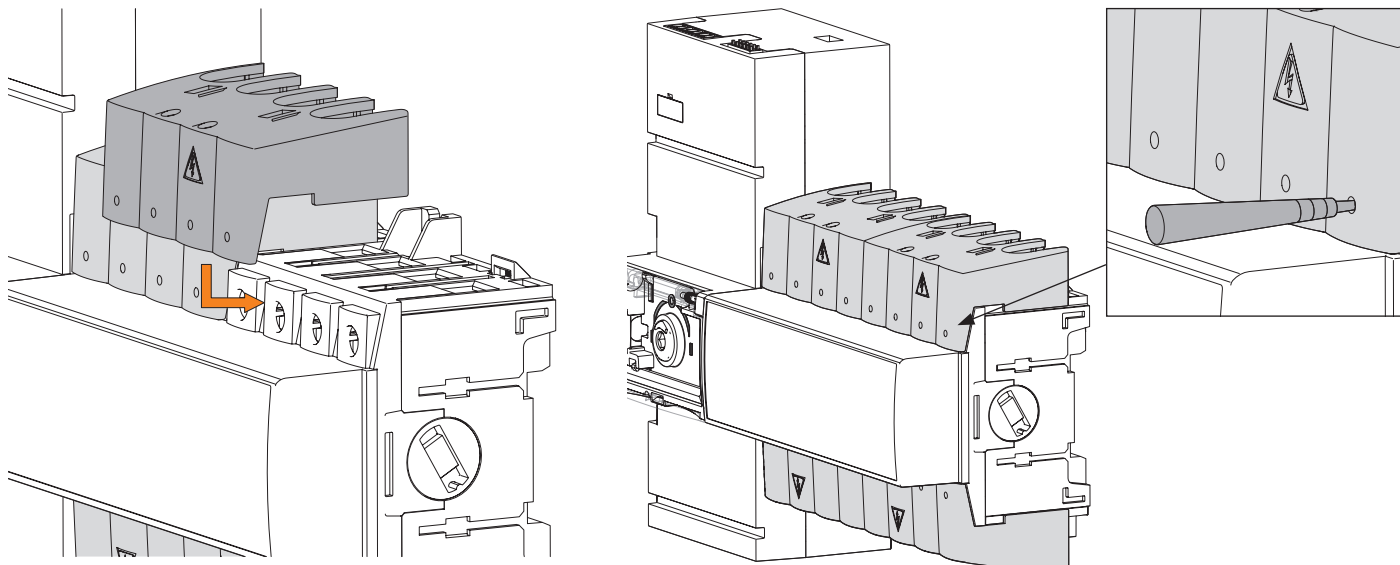

9.4. Terminal shrouds

Ref. 9324 0002.

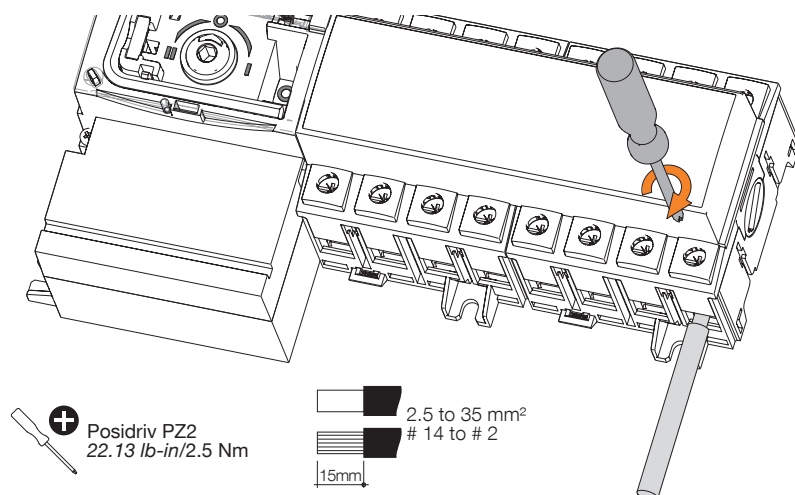

10. CONNECTION OF THE POWER CIRCUITS



 It is essential to tighten all used terminals, with cables and/or bridging bars, before use.

10.1. Ratings / cross-sections table of correspondence

	25 A	32 A	40 A	63 A
Min cable size recommended (mm ²)	2,5	2,5	2,5	2,5
Max cable size recommended (mm ²)	35	35	35	35

 Not compatible with aluminium cables

10.2. Three phase without neutral network

For three-phase networks without neutral, a neutral must be recreated to allow the ATyS a M control to operate. To recreate the neutral, we recommend the use of two auto-transformers connected as shown below. The neutral position on ATyS a M is pre configured on the left of the product, as indicated by the «N» labels.

Auto-transformer connections

Reference 1599 4121

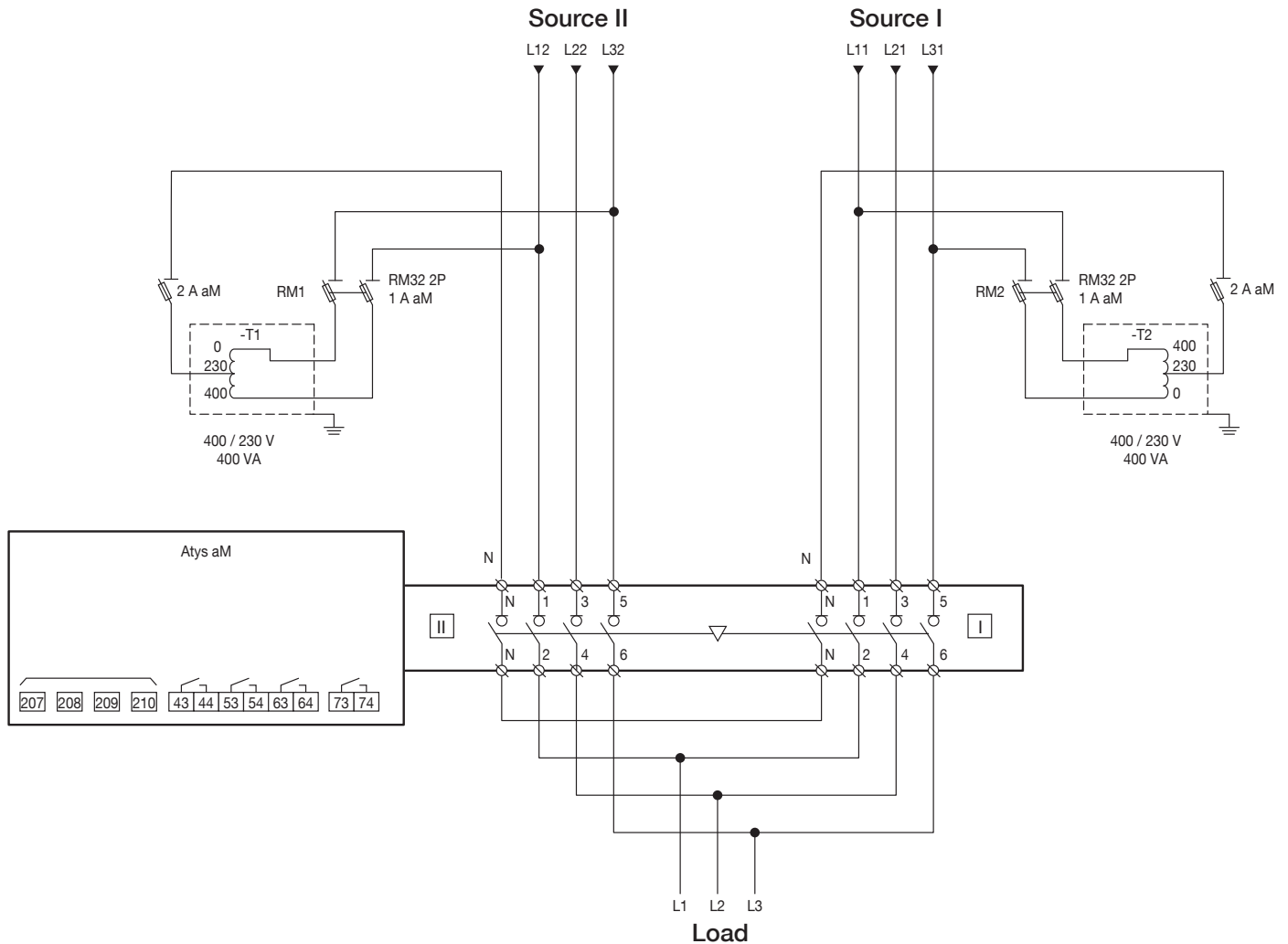

11. CONNECTION OF CONTROL/COMMAND CIRCUITS



Switch to manual mode before connecting the product. (Front Auto/Manu cover open).
The product is delivered in the 0 position.

Ensure that the product is in Manual Mode (front cover open).



11: POP Output
12: POP Output

1: Position 0 Order (Main-Main)/
Test on Load (Main-Gen)
2: Priority S1 / Priority S2
3: Retransfer Mode Selector
4: Inhibit Mode
5: Common

11
12
1
2
3
4
5

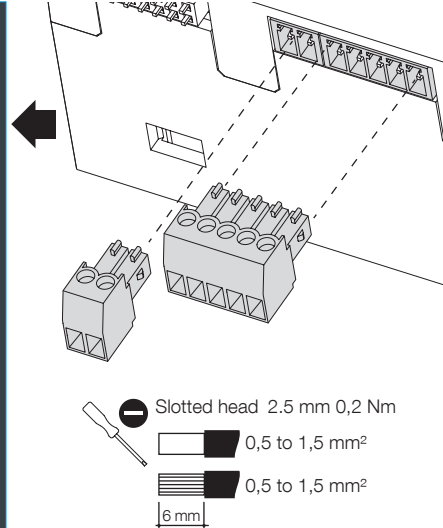

All pressure on the connector pins is to be avoided during wiring of the auxiliary cables



The product is delivered in the 0 position and in auto mode. Maximum control cables length = 10 m. In case of longer distance, use control relays.

Source must always be connected as show above.

11.1. Terminal connectors designation

Type	Terminal no.	Description	Characteristics	Recommended connection cross-section
Inputs	1	Position 0 order (Main-Main) Test on load (Main-GenSet)	Dry potential free contact	0,5 to 1,5mm ² (rigid & stranded)
	2	Priority S1 / Priority S2		
	3	Retransfer mode selector		
	4	Inhibition mode		
	5	Common		
Outputs	11/12	Product operational POP output	External 24V±10% 20mAdc max	0,5 to 1,5 mm ² LiYCY cables
Fire input optional module	-	24Vdc fire input signal	8.6 - 28Vdc	
GenSet output optional module	-	GenSet start and stop management	NC - 230Vac/3A	
RS485 optional module	-	Modbus RTU communication	Non isolated	0,5 to 1,5 mm ² LiYCY cables
Auxiliary contacts unit.	11/12/14	Position I	Dry potential free contact 250Vac 5A AC1 24Vdc 2A	0,5 to 2,5 mm ² (rigid) 0,5 to 1,5 mm ² (stranded)
	21/22/24	Position II		
	01/02/04	Position 0		

Type	Terminal no.	Status of the contact	Description	Output characteristics	Recommended connection cross-section
Auxiliary contact block 1309 1001	11/12/14	11— ⁻¹⁴ / ₁₂	Changeover switch in position I	250V AC 5A AC1 24VDC 2A AC13 - 250VAC - 2A	0,5 to 2,5 mm ² (rigid)
	21/22/24	21— ⁻²⁴ / ₂₂	Changeover switch in position II	250V AC 5A AC1 24VDC 2A AC13 - 250VAC - 2A	
	01/02/04	01— ⁻⁰⁴ / ₀₂	Changeover switch in position 0	250V AC 5A AC1 24VDC 2A AC13 - 250VAC - 2A	0,5 to 1,5 mm ² (stranded)

11.2. Auxiliary contact operating schedule

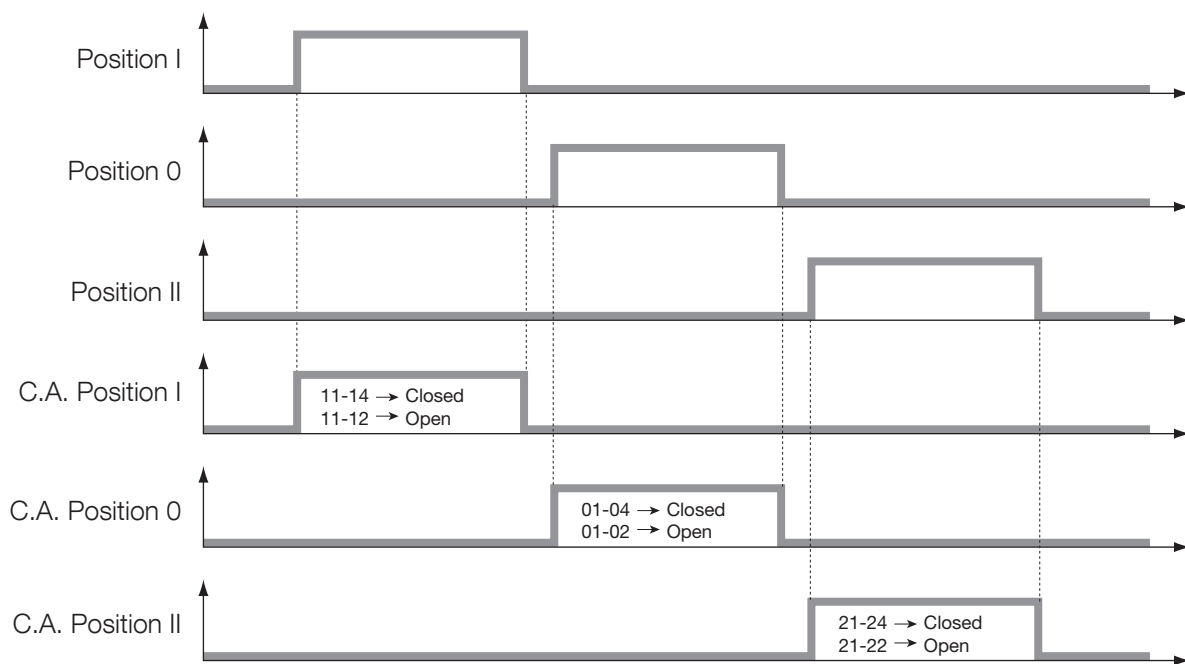

12. OPERATION

12.1. Presentation of the product interface

12.1.1. Product interface

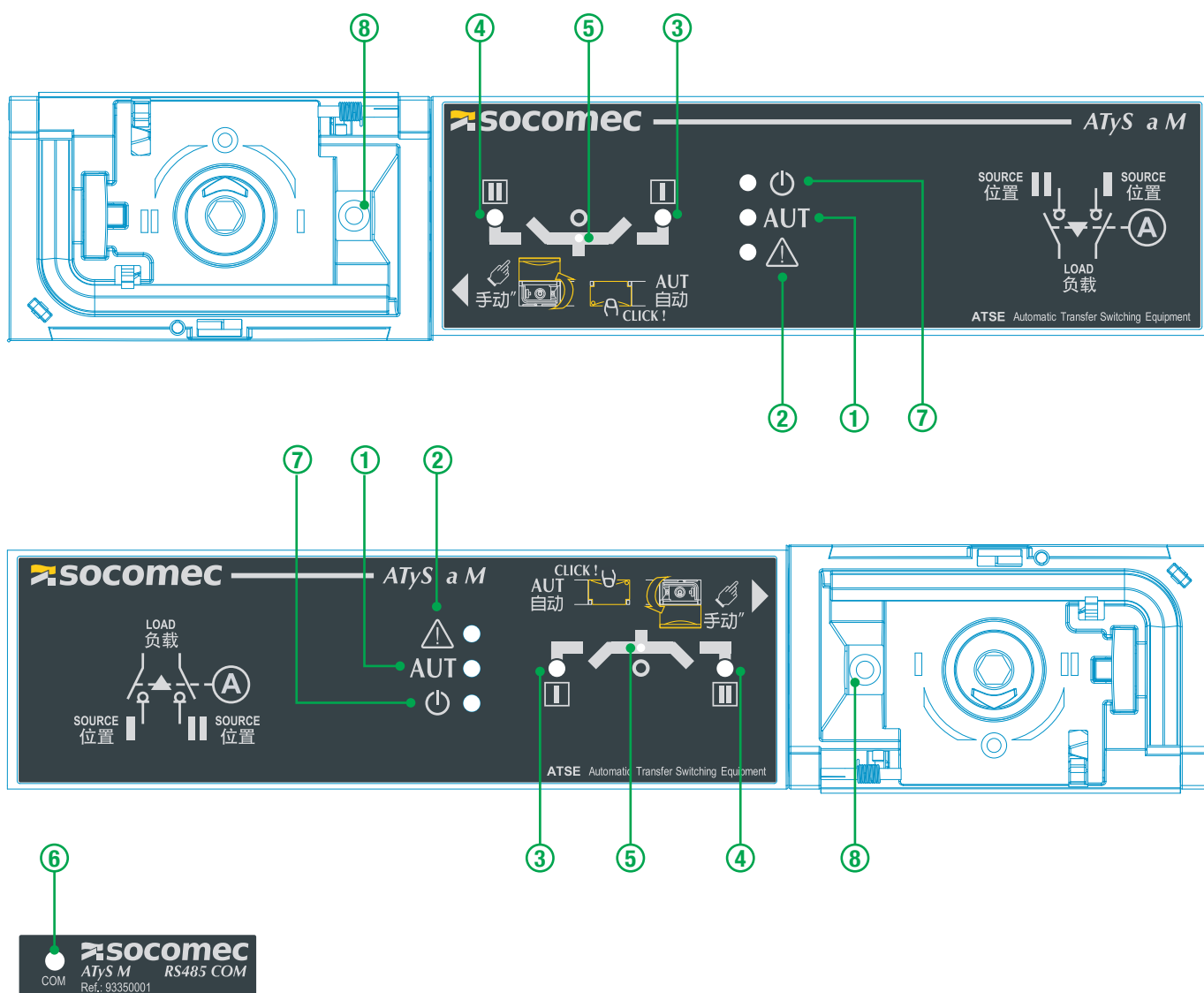

#	Name	Function	Colour	Behaviour
1	AUTO	AUTO/MANU mode information	Green	ON when AUTOMATIC mode activated. OFF when AUTOMATIC mode not activated. Mode can be Manual, Remote or Inhibited. BLINKING (1sec) when a timer is running. FAST BLINKING (200ms) when waiting for retransfer.
2	Warning	Fault indication	RED	OFF when no warning. ON in case of inhibition mode, phase rotation error. BLINKING (1sec) in case of major fault : GenSet fail to start, operating factor reached (too much operations), transfer failed, unknown position. FAST BLINKING (200ms) if Phase/Neutral cabling inversion.
3	Source I	Source I availability information	Green	ON when source I available. BLINKING (1sec) when source I present but not available for following possible reason: - Source under voltage / under frequency - Source over voltage /over frequency - Phase rotation order of source 1 & 2 are different OFF when source I unavailable.
4	Source II	Source II availability information	Green	ON when source II available. BLINKING (1sec) when source II present but not available for following possible reason: - Source under voltage / under frequency - Source over voltage /over frequency - Phase rotation order of source 1 & 2 are different OFF when source II unavailable.
5	Position 0	ATyS in 0 position	Orange	ON when product is in position O.
6	RS485 communication (if present)	Modbus communication activity	Orange	BLINKING when controller is sending / receiving information. OFF : No communications orders are currently being sent or received.
7	POWER ON	ATyS is supplied	Green	ON: product is well supplied.
8	Position indicator	Switch position indication	Yellow	I, O or II physical position information by mechanical indicator, linked to the switch power mechanism.

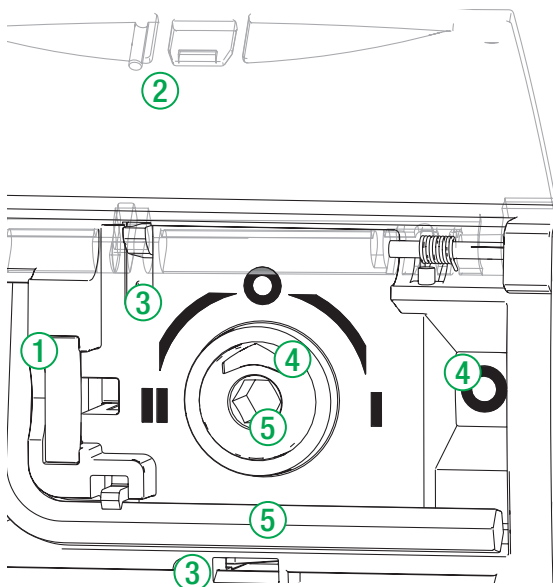

1. Locking

- Mechanism to padlock using a 1 x 8 mm max. padlock.

2. AUT/MAN cover

- Open the cover to switch to manual mode.
- Close the cover to return to automatic (remote control) mode.
- Open and close the cover to clear faults.

3. Auto/Manual mode sensor

4. Switch position indicators

- Display of position I, O, II.

5. Manual switching

- Insert the Allen key (5.0 mm) provided and turn to switch manually.
- Manual operation is not possible when padlocked.

12.1.2. Reset

Operating fault reset

Open and re-close the AUT/MAN cover

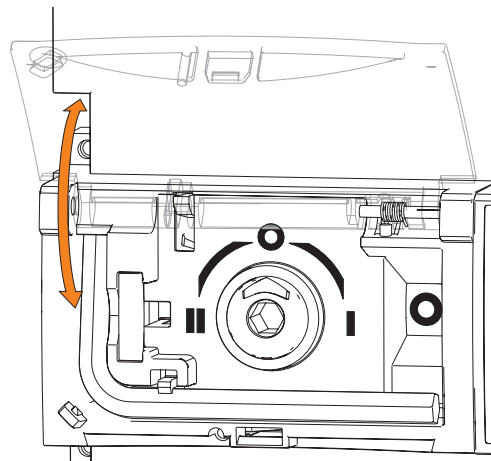

12.2. Manual mode

To access manual mode, open the Aut/Man cover.

Once manual mode is active (cover open) it is possible:

- To lock the changeover switch.
- To manually operate the changeover switch using the handle.

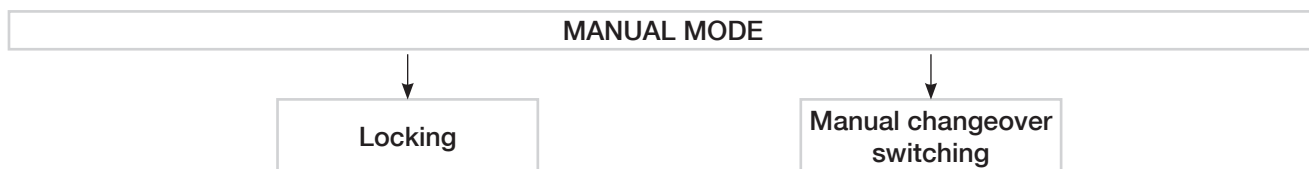
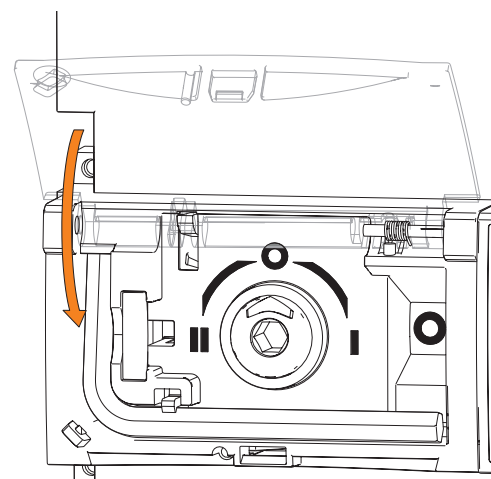

12.3. Manual switching

Use the handle situated on the front panel under the cover to manoeuvre the changeover switch. To simplify the operation, it is advised to also use the handle extension that is delivered with the product.

Check the changeover switch position on the indicator situated on the front panel before making any operation.

- From position I, turn anti-clockwise to get to position 0
- From position 0, turn anti-clockwise to get to position II
- From position II, turn clockwise to get to position 0
- From position 0, turn clockwise to get to position I

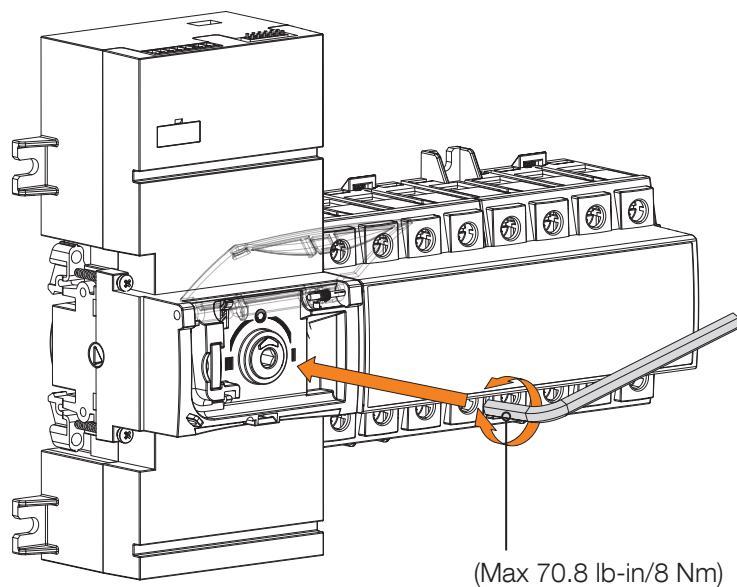

12.4. Padlocking

Locking is only possible in manual mode (cover open).

Pull on the locking handle to enable the interlock. Lock by inserting a padlock into the orifice provided for this purpose.

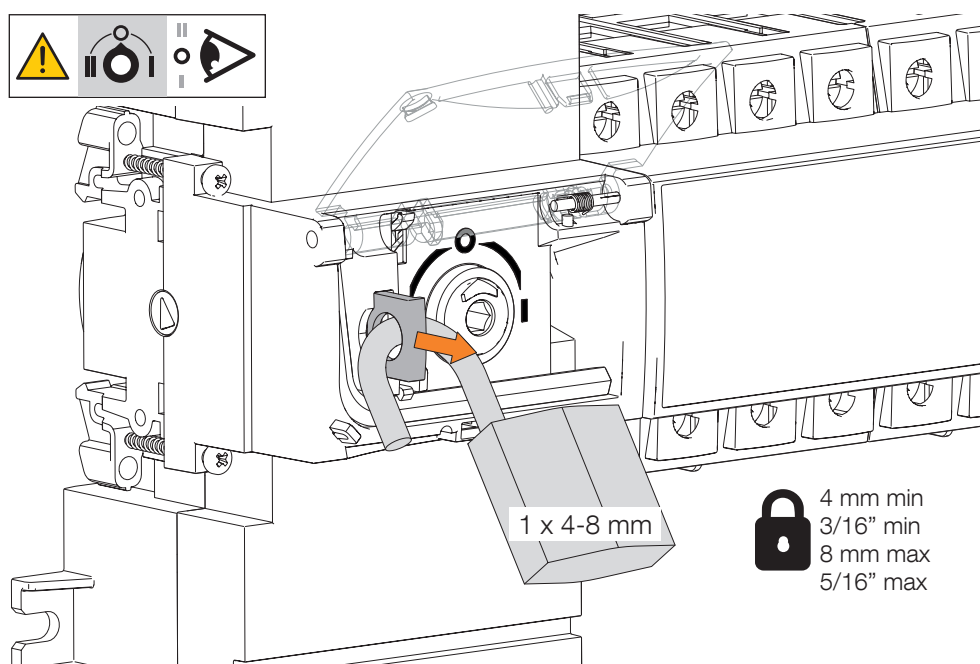

12.5. Power ON

Whilst in manual mode check the wiring and installation. If ok power up the product.

This product must always be put into service by qualified and authorised personal.

The LED signalling is only active when the product supply is on (supply LED lit).

The commissioning must always result in having at least 1 LED source available lit.

Therefore, the voltage and frequency must be within the defined thresholds.

12.6. Automatic mode

Close the cover to enter automatic mode. Make sure that the changeover switch is in automatic mode (AUT LED lit).

12.6.1. Sealable Auto/Manual cover

Auto/Manu mode can be protected by sealing the standard Auto/Manu cover as shown.

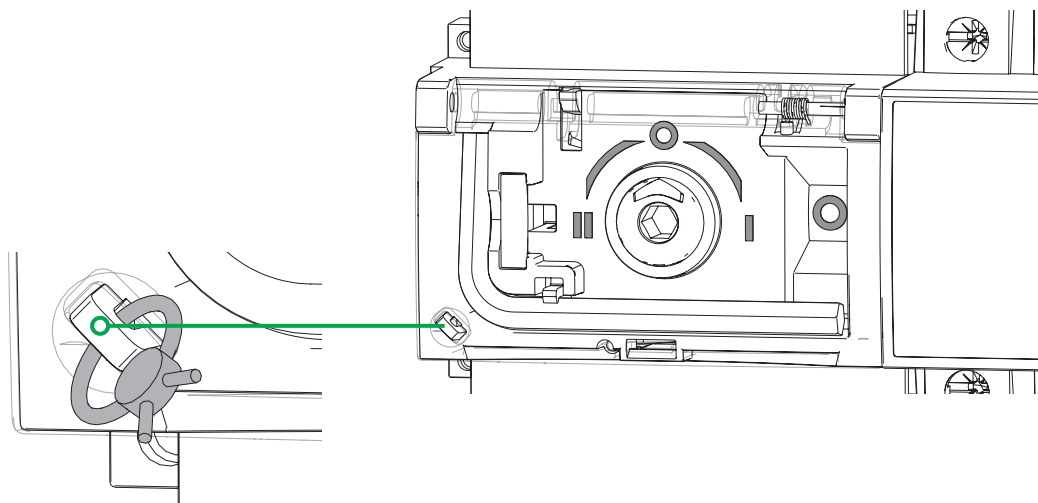

Preset parameters

- Nominal voltage: 380Vac
- Source voltage hysteresis +/- 15%
- Sources phases rotation check
- Source voltage threshold +/- 20%
- Source frequency threshold +/- 10%

Timer mnemonic	Timer name	Timer description	Timer factory setting
1RT	Source I return timer	When source 1 returns inside the limits, 1RT is started. At the end of 1RT, source 1 is then considered to be available. Should source 1 unavailable before the end of 1RT, the changeover will not be carried out.	2sec
1FT	Source I failure timer	When source 1 is considered unavailable, 1FT is started. If source 1 is considered restored (available again) before the end of 1FT, the changeover sequence will not be engaged.	2sec
2RT/2AT	Source II return timer / Source II Availability timer	When source 2 returns inside the limits, 2RT is started. At the end of 2RT, source 2 is then considered to be available. Should source 2 unavailable before the end of 2RT, the changeover will not be carried out.	2sec
2FT	Source II failure timer	When source 2 is considered unavailable, 2FT is started. If source 2 is considered restored (available again) before the end of 2FT, the changeover sequence will not be engaged.	2sec
ODT	0 dead timer	Minimum load downtime possibility with stop in position 0; to enable residual voltage generated by the load to disappear.	0sec
DRT	Dynamic return timer	This timer is used to replace the return timer of the priority source in case of a retransfer back to main source, if we lost the backup source while the return timer is counting.	3sec
2CT	GenSet cooldown timer	In Main-GenSet application, following a return to the priority source (when it is closed), the genset is kept running for the 2CT timer duration. This timer is intended to cool down the genset (off load) before switching it off.	180sec
2ST	GenSet start timeout timer	"In Main-GenSet application, this timer is used to know if genset has started and turned available (end of 2AT) fast enough. Timer start as soon as the genset start order has been given. If 2AT has not been satisfied before the end of this timer, an error will be raised (GenSet failed to start). In AUTO mode this timer does not affect the genset start request. During a test sequence, the test will be cancelled and the genset turned OFF."	30sec

12.7. Possible actions

Once in automatic mode, it is possible to:

- Run a source **I** / source loss sequence **II**,
- Start a restoration sequence source **I** / source **II**.

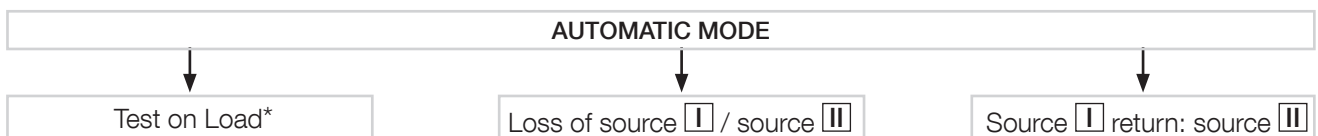

*If GenSet output module is present.

On load test (M-G application only): this test is only possible in automatic mode, it enables to start the GenSet and simulate a complete transfer sequence, including time delays.

NORMAL > EMERGENCY CYCLE - Transformer-Transformer application

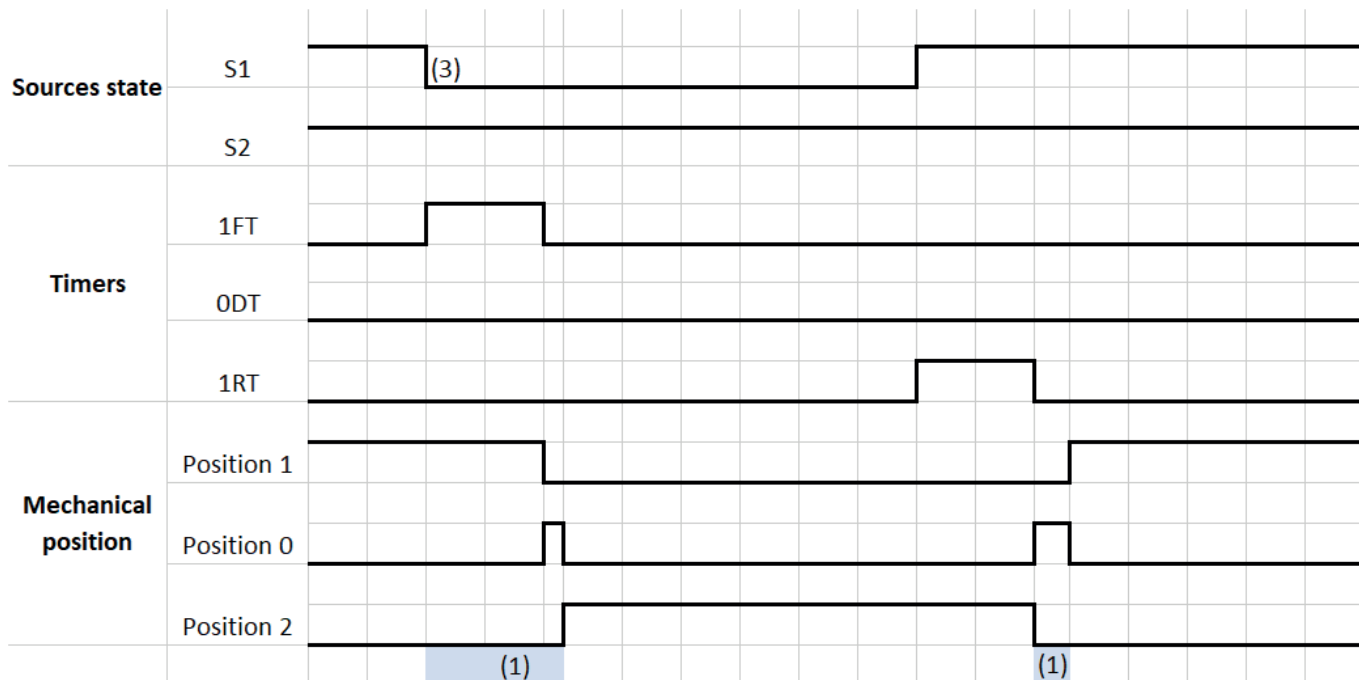

- (1) Total blackout duration.
- (2) ODT starts counting as soon as switch is on position 0.
- (3) Source 1 is completely OFF (all phases <50V).

NORMAL > EMERGENCY CYCLE - Transformer-Genset application

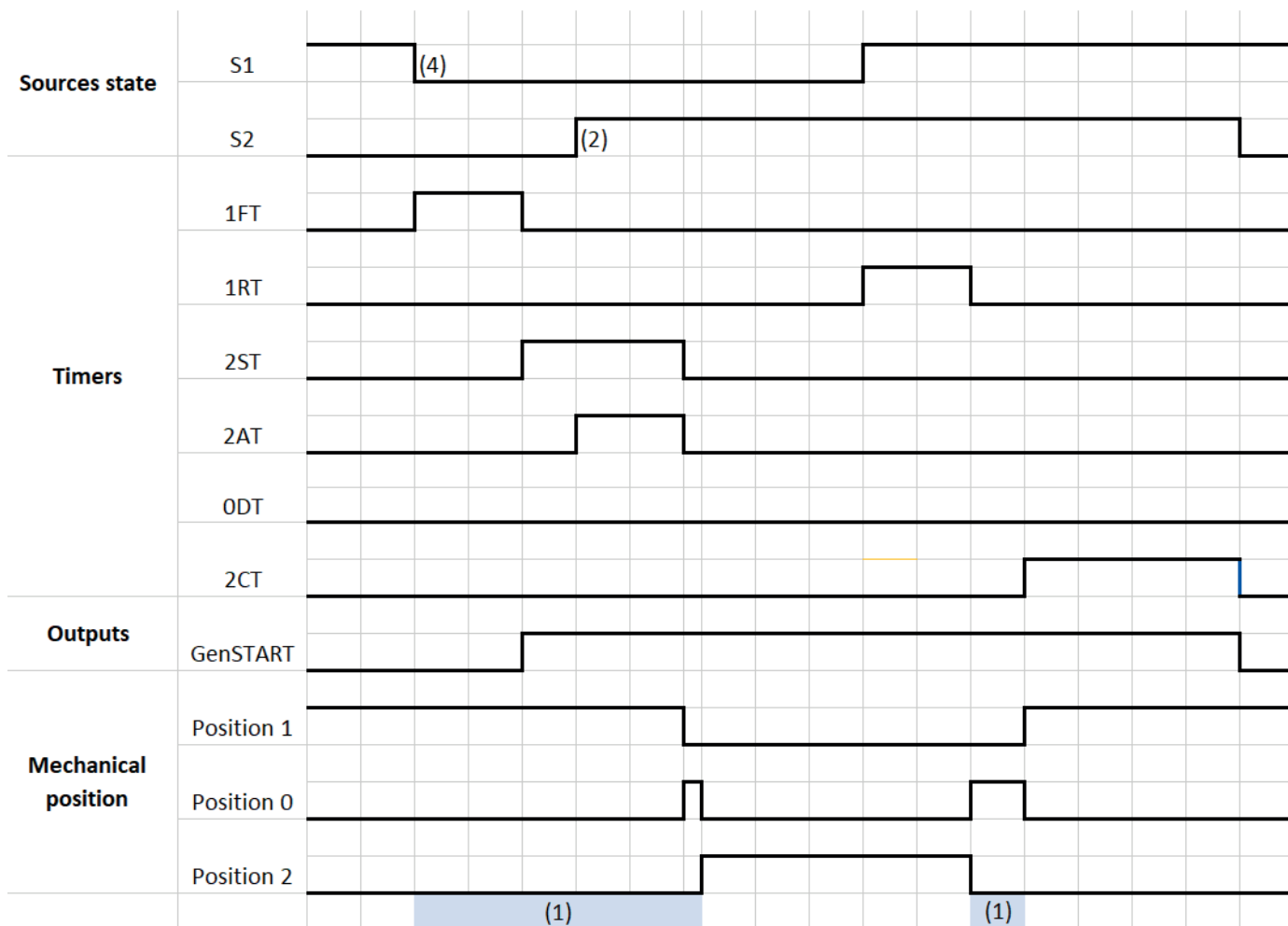

- (1) Total blackout duration.
- (2) Genset is initially OFF, and slowly starts after activation of genSTART contact.
- (3) ODT starts counting as soon as the switch is on position 0.
- (4) Source 1 is completely OFF (all phases <50V).

12.8. Optional modules operation

12.8.1. RS485 communication module

Communication via an RS485 connection (Modbus® protocol) enables you to connect up to 31 ATyS to a PC or a programmable logic controller.

Maximum distance is 1200 metres with 120 Ohms terminal resistors at both ends of the bus.

If the distance of 1200 m and / or the number of 31 ATyS is exceeded, it is necessary to connect a repeater to enable an additional connection of ATyS over more than 1200 m. For further information on the connection methodology, please consult us.

Address: 1 to 247. Factory setting is 5

Baudrate: 9600 / 19200 / 38400 (factory setting) / 57600 / 115200 Bds

Parity: None (factory setting) / Odd / Even

Stop bit: 1 (factory setting) / 2

12.8.2. Fire input module

24vdc signal comes from an external fire system. When fire linkage is active:

- ATyS a M is forced to 0 position (center-off).
- Inhibition mode is activated. When Fire signal is not active anymore, the previous mode is restored.
- Alarm is activated (LED and communication)

Maximum cable length: 100m.

Main-Main application:

- if opposite source is acceptable for commutation (voltage, frequency and phase rotation), normal behavior is done (go to 0 then inhibition)
- if opposite source is not present (or not within acceptable tolerances), inhibition mode is set, and if opposite source gets acceptable, move to position 0 to disconnect the load while being still inhibited.

Main-GenSet application:

- ATyS is on the main source, and GenSet is not started: ATyS will not start the GenSet for safety reasons, and inhibition mode is set. If in that case, main source is lost, ATyS will be powered OFF and monostable genset relay will start by itself. Product is still inhibited but since there is now energy in opposite source, switch will move to position 0. Inhibition remains, and GenSet is kept ON to power the product whatever if main source comes back.
- ATyS is on the GenSet, main source is not present. Inhibition immediately, and if main returns, ATyS goes to position 0 while inhibition is still active, GenSet is kept ON. When Fire signal is removed, ATyS transfers to Main source if available, and cooldown timer is launched. If main is not available, ATyS goes back on GenSet.
- ATyS is on the GenSet, main is available, case of a test on load: ATyS goes to 0 and GenSet stays ON.

If test is launched from the input connector, and input is still active, after releasing the Fire signal the test continues and ATyS goes back to the GenSet.

If test is launched from communication layer, being in position 0 will stop the test.

- ATyS is on the main source, and GenSet is cooling down: ATyS goes to position 0, raises inhibition mode and GenSet is kept ON. When Fire signal is removed, ATyS goes back to main source and a new cooldown timing is launched.

12.8.3. GenSet output module

Monostable relay working in normally closed (NC) mode. When the output is not powered, the relay is closed, so GenSet start order is sent if ATyS is no more supplied, due to power failure.

Once GenSet output module plugged, ATyS a M automatically adapt settings to Main/GenSet application and input 1 to Test On-load.

GenSet start and stop orders are sent according to timers:

- Sources failure timer (1FT / 2FT), factory setting = 2s. (in case of source loss, FT is not counted and start order sent)
- Sources return timer (1RT / 2RT), factory setting = 2s.
- GenSet start timeout (2ST), factory setting = 30s.
- GenSet cooling timer (2CT), factory setting = 180s.

Maximum cable length: 100m

13. MAINTENANCE

It is recommended to operate the product at least once a year.

I - O - II - O - I

Note: Maintenance should be planned carefully and carried out by qualified and authorised personnel. Consideration of the critical level and application where the product is installed should form an essential and integral part of the maintenance plan. Good engineering practice is imperative whilst all necessary precautions must be taken to ensure that the intervention (whether directly or indirectly) remains safe in all aspects.



The use of any Megohmmeter is prohibited on this product as the connection terminals are intrinsically connected to the sensing circuit.

14. TROUBLESHOOTING GUIDE

Problem	Actions	Expected results
Product is off, i.e. no LEDs are ON.	Check for 176-264VAC across terminals 1 and 7 on switch I and II.	The ON LED is powered.
SOURCE1 availability LED is OFF.	Voltage and frequency auto configuration: - Step 1: open manual operation cover. - Step 2: re-close the cover.	SOURCE 1 LED is ON.
	Check the value of the voltage and frequency thresholds (Easy Config System software). Set to maximum level and reduce later if applicable.	
	Check the following parameters: - network type: Must be a 3 phase network + neutral (or transformer), - nominal voltage: Must be between 176 and 264 Vac, - nominal frequency: Must be between 45 and 65 Hz.	
SOURCE 2 availability LED is OFF.	Voltage and frequency auto configuration: - Step 1: open manual operation cover, - Step 2: re-close the cover.	SOURCE 2 LED is ON.
	Check the value of the voltage and frequency thresholds (Easy Config System software). Set to maximum level and reduce later if applicable.	
	Check the following parameters: - network type: Must be a 3 phase network + neutral (or transformer), - nominal voltage: Must be between 176 and 264 Vac, - nominal frequency: Must be between 45 and 65 Hz.	
Switch remains off after loss of Priority source ; i.e. no LEDs are ON.	Check for 176-264VAC across power terminals 1 and 7 on switch II.	The AUT LED is ON with manual operation cover closed.
The switch does not transfer after loss of priority source.	Check that the product is not in manual mode: - Automatic mode = Cover closed - Manual mode = Cover open.	The AUT LED is ON.
	Check that automatic operation has not been inhibited by an external order (input terminals 4-5).	The AUT and the backup SOURCE LEDs are ON.
	Check that the backup source is seen as available ; appropriate source availability LED is ON. If it is not ON refer to above actions for "SOURCE x availability LED is OFF". Check that automatic operation has not been inhibited by an external order (input terminals 4-5).	
	The changeover will only take place at the end of FT.	When FT reaches zero the switch will operate to position 0 before finally transferring to its backup position.
The switch does not return to its priority position after the priority source has been restored.	Check that the product is not in manual mode: - Automatic mode = Cover closed, - Manual mode = Cover open.	The AUT LED is ON.
	Check that automatic operation has not been inhibited by an external order (input terminals 4-5).	The AUT and the priority SOURCE LEDs are ON.
	Check that the priority source is seen as available ; appropriate source availability LED is ON. If it is not ON refer to above actions for "SOURCE x availability LED is OFF".	
	The changeover will only take place at the end of RT.	When RT reaches zero the switch will operate to position 0 before finally transferring to its priority position.

CORPORATE HQ CONTACT:
SOCOMECSAS
1-4 RUE DE WESTHOUSE
67235 BENFELD, FRANCE

www.socomec.com

Non contractual document. © 2024, Socomec SAS. All rights reserved.



552533B



 **socomec**
Innovative Power Solutions