

ITYS E

from 1 to 3 kVA - Mini Tower

Installation and operating manual (GB)

WARRANTY CERTIFICATE AND CONDITIONS

This SOCOMEC appliance is guaranteed against manufacturing and material defects for a period of 12 months from the date of purchase (local warranty conditions are applicable in addition to the general conditions). This warranty certificate should NOT be e-mailed, but kept by the customer along with proof of purchase, for use in the event of a claim being made for repairs or replacement under warranty.

The warranty period commences on the date the new product was purchased by the end user at an authorised showroom (reference details are shown on the receipt).

Return-to-base warranty is provided: components and labour for repairs supplied free of charge, any products to be replaced must be returned to SOCOMEC or authorised service centres, at the customer's own risk and expense.

The warranty is recognized within national territory. If the UPS is exported out of national territory, the warranty shall be limited to the cover of the parts used to repair the fault.

To claim service under the warranty please observe the following:

- The product must be returned in the original packing. Any damage caused during shipping in packaging other than the original will not be covered by the warranty;
- The product must be accompanied by proof of purchase such as an invoice or receipt indicating the date of purchase and product ID information (model, serial number). The sender must also attach the reference number issued to authorise the return of the product, together with a detailed description of the defect. If any of this information is missing the warranty will be invalid. The authorisation number is issued by service centres over the telephone on receiving information on the malfunction in question;
- If it is not possible to provide proof of purchase the serial number and date of manufacture will be used to calculate the probable expiry date of the warranty; this could result in a reduction of the original warranty period.

The warranty on the product does not cover damage caused by carelessness (improper use: wrong input power, explosions, excessive humidity, temperature, poor ventilation, etc.), tampering or any unauthorised repair work.

During the warranty period, SOCOMEC reserves the right to decide whether the product should be repaired, or whether to replace defective parts with new parts, or used parts that are equivalent to new parts in terms of functionality and performance.

In the case of batteries, warranty is valid only if the battery has been recharged regularly in accordance with the manufacturer's instructions. On purchasing the product it is advisable to check that the next recharge date indicated on the packaging has not expired.

Battery

- Batteries are treated as consumable parts and warranty only covers manufacturing defects.
- Batteries must be stored in compliance with Supplier recommendations.
- Warranty is valid only if the battery has been recharged regularly in accordance with the manufacturer's instructions. On purchasing the product it is advisable to check that the next recharge date indicated on the packaging has not expired.

Optionals

A 12-month return-to-base warranty is provided on optionals.

Software products

Software products are guaranteed for 90 days. The software is guaranteed to work as indicated in the manual accompanying the product. Hardware media or accessories (e.g. diskettes, cables, etc.) used with appliances are guaranteed free of material or manufacturing defects under normal conditions of use for a period of 12 months from the date of purchase.

SOCOMECEC will not be responsible for damages (including loss of income, interruption of business activity, loss of information or other financial losses, of any nature) arising from the use of the product.

These conditions are subject to Italian law. Disputes shall come under the jurisdiction of Court of Vicenza.

SOCOMECEC retains the full and exclusive ownership rights over this document. Only a personal right to utilize the document for the application indicated by SOCOMEC is granted to the recipient of such document. All reproduction, modification, dissemination of this document whether in part or whole and by any manner are expressly prohibited except upon Socomec's express prior written consent.

This document is not a specification. SOCOMEC reserves the right to make any changes to data without prior notice.

TABLE OF CONTENTS

1. SAFETY STANDARDS	4
1.1. IMPORTANT	4
1.2. DESCRIPTION OF THE SYMBOLS	5
2. ENVIRONMENTAL REQUIREMENTS AND MOVING	6
2.1. ENVIRONMENTAL REQUIREMENTS	6
3. ELECTRICAL INSTALLATION	8
3.1. ELECTRICAL REQUIREMENTS	8
4. OVERVIEW	9
5. CONNECTIONS	11
5.1. EXTERNAL BATTERY CONNECTION	11
6. MENU	12
6.1. DISPLAY OVERVIEW	12
6.2. MENU FUNCTIONS DESCRIPTION	13
7. OPERATING PROCEDURES	15
7.1. SWITCHING ON	15
7.2. SWITCHING OFF	15
7.3. BATTERY OPERATIONS	16
8. OPERATING MODES	17
9. STANDARD FEATURES AND OPTIONAL	18
10. WARNING AND TROUBLESHOOTING	19
11. TECHNICAL SPECIFICATION	21

1. SAFETY STANDARDS

1.1. IMPORTANT

This manual should be kept in a safe place near the UPS, so it can be consulted by the operator at any time for information that may be needed regarding correct use of the unit. Read the manual carefully before connecting the unit to the a.c. mains supply and the downstream appliances. Before the UPS is put into commission the user should be completely familiar with its operation, the position of all the controls and the technical and functional characteristics of the unit, so as to ensure there will be no risk to people or the appliance itself.

- Before being started, the unit must be equipotentially bonded, in accordance with current safety regulations. The earth wire of the UPS must then be connected to an efficient earth system.
- If there is no earth connection, the appliances connected to the UPS will not be equipotentially bonded. In this situation, the manufacturer declines all liability for any damage or accidents that could result from failure to observe the requirements.
- Should a power outage occur (UPS in stand-alone mode), do not disconnect the power cord from the mains, as this will break the earth connection to bonded appliances.
- All subsequent maintenance operations must only be performed by authorised service engineers. The UPS generates high internal voltages that could be hazardous for a maintenance operative not in possession of the appropriate skills and training for this type of work.
- If a hazardous situation should arise at any time when the UPS is in use, isolate the unit from the power supply (by operating a switch at the upstream PDU if possible) and switch the appliance off completely by running the shutdown procedure.
- The UPS houses a source of electrical energy, i.e. its batteries. The output of the UPS may be powered even when the appliance is not connected to the a.c. mains supply.
- Never force, break or attempt to open the batteries. These batteries are sealed, maintenance-free components containing substances that are harmful to health and a source of environmental pollution. If liquid can be seen leaking from the battery, or a white powdery residue is noticeable, do not switch the UPS on.
- Avoid exposing the UPS to contact with water or any liquids generally. Do not insert foreign objects into the cabinet.
- Danger of explosion if the batteries are replaced with others of the wrong type.
- Replaced batteries must be disposed of at authorised waste disposal centres.



It is very dangerous to touch any part of the batteries as there is no insulation between the batteries and the mains power source.



CAUTION!
A battery can present a risk of electrical shock and high short circuit current.

- If the appliance is to be disposed of it should only be entrusted to a specialist waste disposal company. These companies will dismantle and dispose of the various components in accordance with statutory regulations in the country of purchase.
- Use the UPS in accordance with the technical specifications indicated in this manual.
- To meet Emergency Switch Device (ESD) operating requirements, a specific input with remote ESD/EPO function is available.
- In the event that the equipment has no automatic backfeed protection contactor device, ensure that:
 - the user/installer attaches warning labels to all mains isolating switches located remotely from the area where the UPS is situated, in order to inform service personnel that the circuit is connected to a UPS.
 - an external isolating device is installed
- The product you have selected, given the specified conditions of use, capacity and performance limits, is designed exclusively for commercial and industrial operation. Using the product in critical applications could require compliance with statutory regulations and standards, specific local bylaws, or adaptation to SOCOMEC recommendations. For this type of use it is always advisable to contact SOCOMEC beforehand for confirmation regarding the capacity of products to meet required levels of safety, performance and reliability. Critical applications include, in particular, life support systems, medical applications, commercial transport, nuclear facilities or any other systems where failure of the product might on occasion cause serious damage to people or property.



WARNING!

This is a product for commercial and industrial applications in an industrial environment – installation restrictions or additional measures may be needed to prevent interference.



**CAUTION IF DAMAGED
NON-SPILLABLE BATTERIES**

Torn, crushed or damaged packaging which exposes the contents should be set aside in an isolated area and inspected by a qualified person. If the package cannot be shipped the contents must be promptly collected, segregated, and either the sender or recipient contacted.

All packaging material must be recycled in compliance with the laws in force in the country where the system is installed.

The product you have chosen is designed for commercial and industrial use only.

In order to be used for particular “critical applications” such as life support systems, medical applications, commercial transportation, nuclear facilities or any other application or systems where product failure is likely to cause substantial harms to person or property, the products may have to be adapted.

For such uses we would advise you to contact SOCOMEC UPS beforehand to confirm the ability of these products to meet the requested level of safety, performance, reliability and compliance with applicable laws, regulations and specifications.

- Since the UPS power cord functions as an isolating device, ensure ready access to the mains power socket where the UPS is connected, and/or the rear panel of the UPS, so the unit can be easily unplugged.
- The UPS generates a leakage current of approximately 2 mA. To guarantee the maximum leakage current of 3.5 mA, ensure the leakage current generated by the load is no greater than 0.5 mA. Should the leakage current from the load exceed this limit, instruct a skilled engineer to install an industrial type connection (to IEC 309 standard) between the UPS and the a.c. mains supply, sized to handle a current compatible with the rating of the appliance.

1.2. DESCRIPTION OF THE SYMBOLS

Comply with all precautions and warnings on labels and plates on the inside and outside of the equipment.



DANGER! HIGH VOLTAGE (BLACK/YELLOW)



GROUND TERMINAL



READ THE USER MANUAL BEFORE USING THE UNIT

2. ENVIROMENTAL REQUIREMENTS AND MOVING

2.1. ENVIRONMENTAL REQUIREMENTS

Consult the following check list when installing the UPS:

- ITYS units are designed for use in enclosed environments.
- Position the UPS on a flat, stable surface in a properly ventilated room, well away from heat sources and avoiding direct exposure to sunlight.
- Ambient temperature should be kept between 0 to 45 °C, and relative humidity below 90% (without condensation); the optimum temperature to maximise battery lifetime is 15 to 20 °C.
- Check that the UPS will not be installed in a dusty environment.
- Take care not to stand the UPS or any other heavy objects on cables.
- Check that the operating voltage and frequency settings are correct for the mains power supply at the installation site. Details for the UPS will be found on the data plate attached to the rear panel.
- When carrying out the RS232 serial connection, use only the cables and accessories supplied or specified by the manufacturer.
- When the UPS is first used, it is advisable to leave the battery on charge for a minimum of 8 hours.
- Condensation may occur if the UPS system is moved directly from a cold to a warm environment. The UPS system must be completely dry before being installed. Please allow at least two hours for the UPS system to become acclimatised to the environment.
- Do not install the UPS system near water or in damp environments.
- Do not connect appliances or devices which would overload the UPS system (e.g. laser printers) to the UPS output sockets.
- Ensure there is a reliable earth connection.
- Ensure external battery sources are earthed.



PRECAUTIONS IN THE EVENT OF DAMAGE DO NOT TURN THE BATTERIES OVER

Torn, crushed or damaged packaging which exposes the contents should be kept separate in a secure area, and inspected by qualified staff. Packing which cannot be shipped must be set aside immediately and kept secure, and the sender or recipient contacted.

- Connect the UPS system to an earthed shockproof outlet only, which is easily accessible and close to the UPS system.
- Do not block ventilation openings on the UPS casing. Ensure the air vents on the front, side and rear of the UPS are not blocked. Ensure at least 25 cm of space at the front and the rear of the UPS, and at least 10 cm on both the sides.

ITYS

from 1 to 3 kVA

ENGLISH

3. ELECTRICAL INSTALLATION

3.1. ELECTRICAL REQUIREMENTS

The fixed power distribution unit must include protection and isolation for the utility supply and the back-up supply. In the event that a residual current device is installed on the UPS input line (optional), this must be located upstream of the power distribution unit.

Electrical requirements			
UPS	Thermal-magnetic switch on input	Input leakage current	Cable section
1 kVA	10 C	< 3.5 mA	according to IEC
2 kVA	16 C	< 3.5 mA	according to IEC
3 kVA	20 C	< 3.5 mA	according to IEC

4. OVERVIEW

Connection to the mains power supply and to the load(s) must be made using cables of suitable cross section, in accordance with current standards.

If not already provided, install a PDU panel allowing isolation of the mains supply upstream of the UPS. The panel must be equipped with an automatic switch rated high enough to handle the current draw on full load, and with a residual current device.

4.1. ITYS-E 1 kVA

ENGLISH

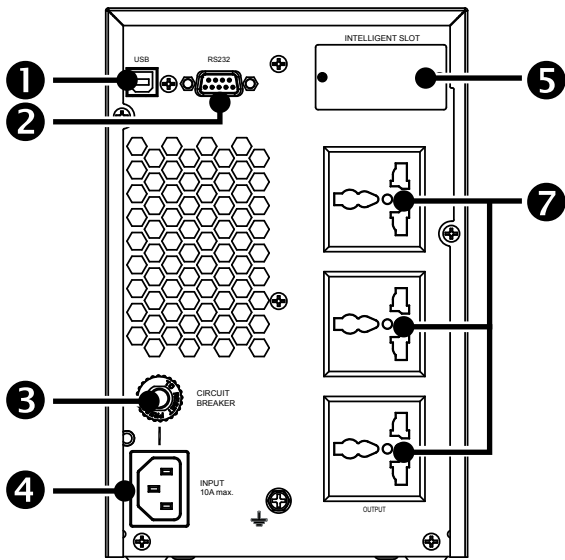

B universal plug

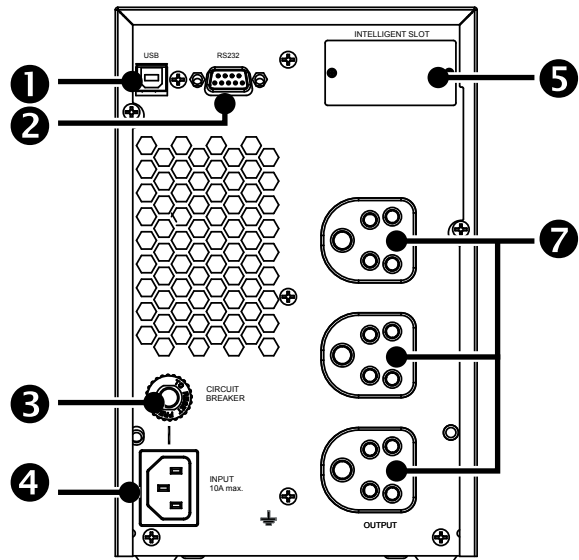

B Indian plug

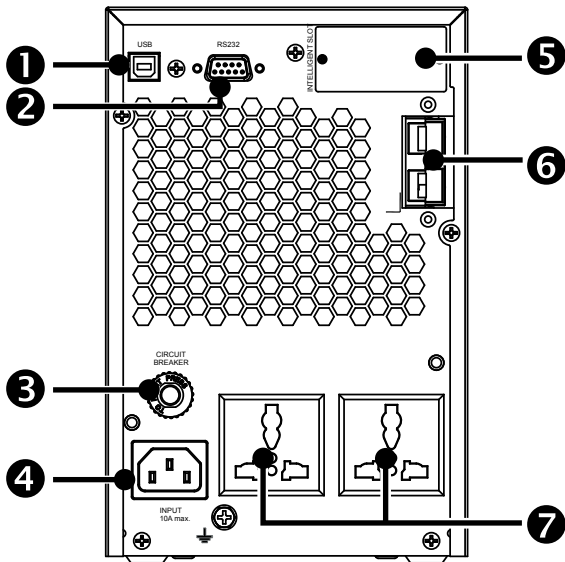

LB universal plug

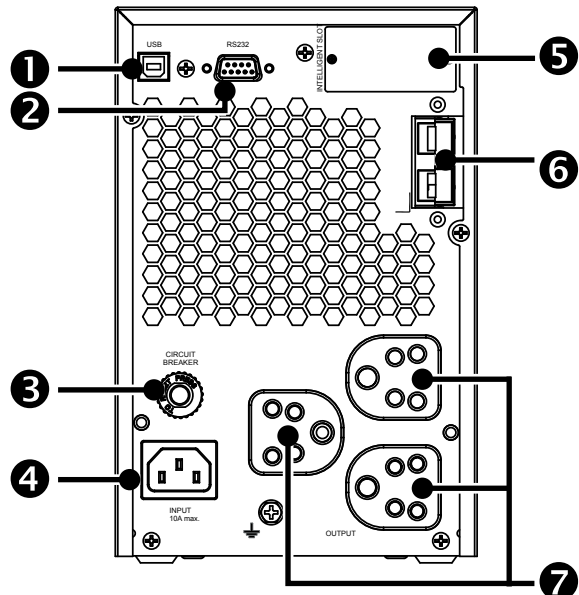

LB Indian plug

- ① USB serial port
- ② RS232 serial port
- ③ Input protection
- ④ Input socket (IEC 320)

- ⑤ Slot for optional boards
- ⑥ External battery
- ⑦ Output sockets (IEC 320)

4.2. ITYS-E 2 kVA

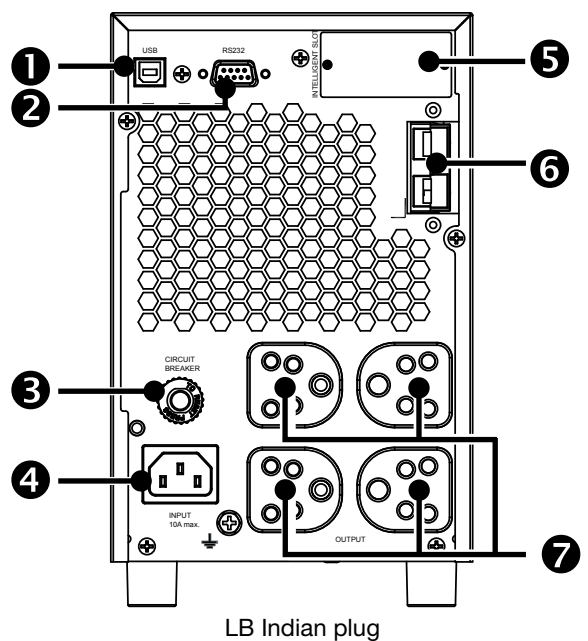
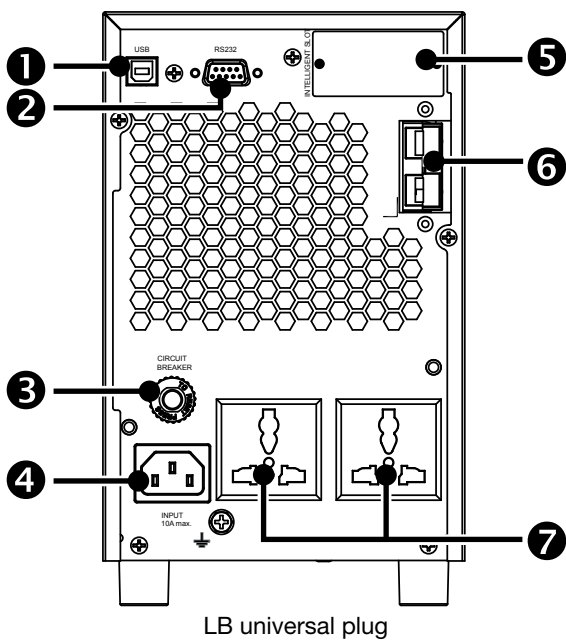
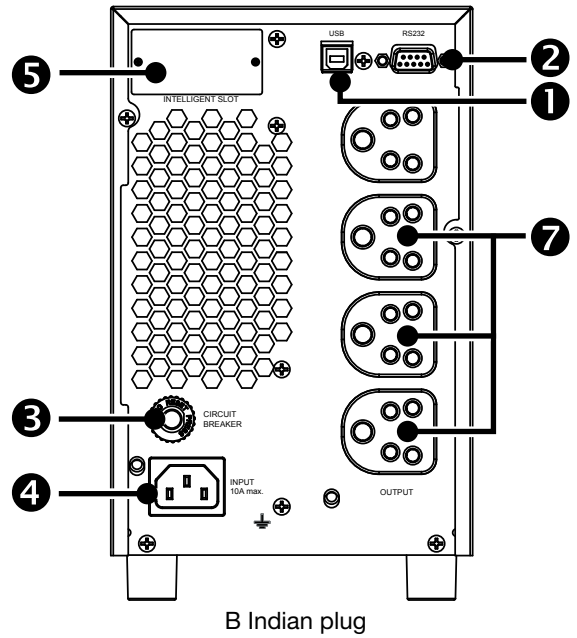
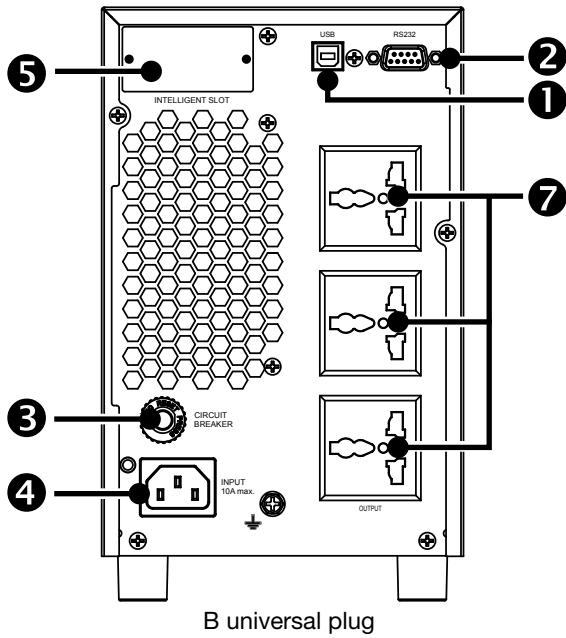

- 1 USB serial port
- 2 RS232 serial port
- 3 Input protection
- 4 Input socket (IEC 320)

- 5 Slot for optional boards
- 6 External battery
- 7 Output sockets (IEC 320)

4.3. ITYS-E 3 kVA

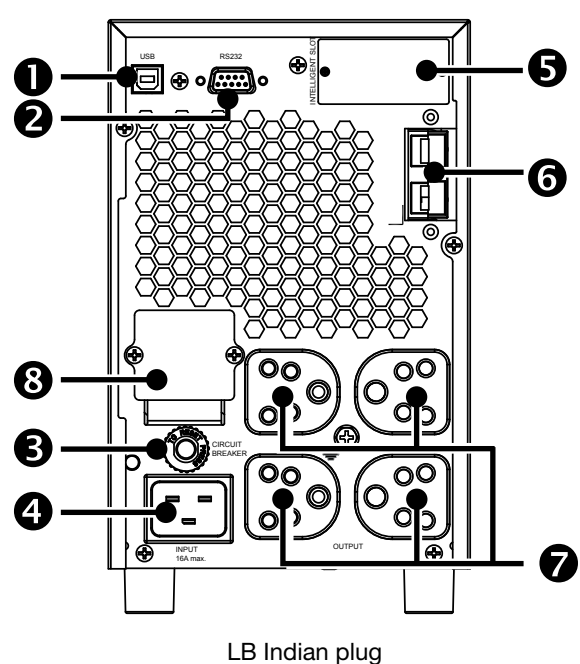
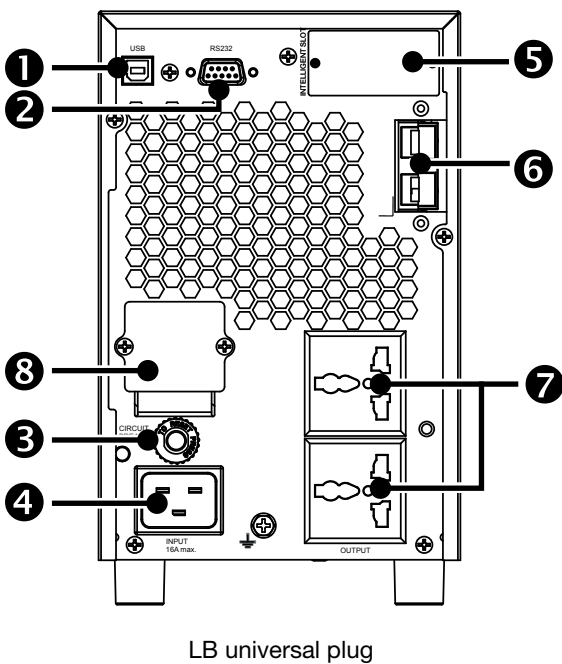
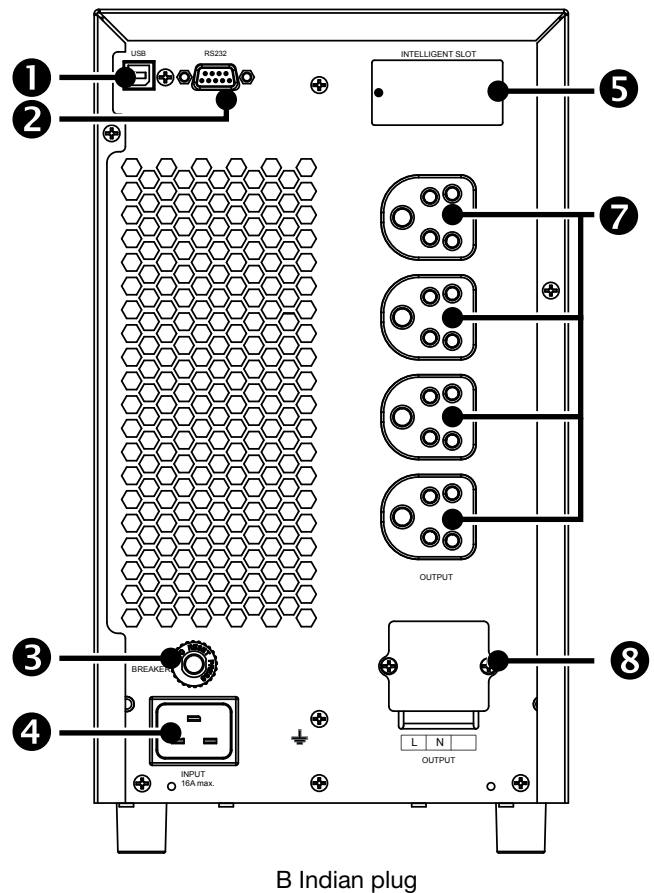
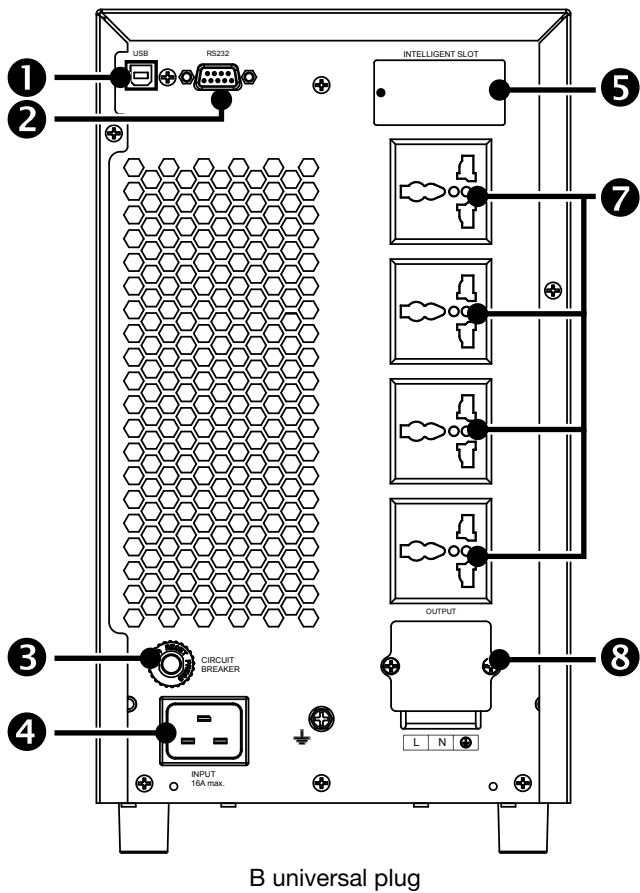

- 1 USB serial port
- 2 RS232 serial port
- 3 Input protection
- 4 Input socket (IEC 320)

- 5 Slot for optional boards
- 6 External battery
- 7 Output sockets (IEC 320)
- 8 Output terminals (full power)

4.4. FULL POWER OUTPUT CONNECTON

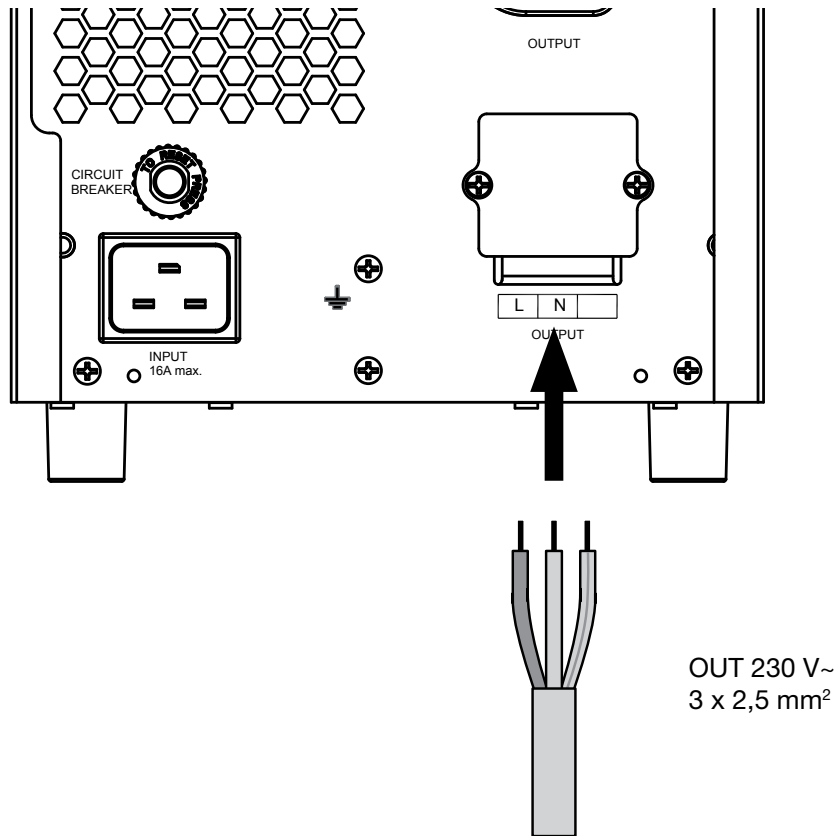

5. CONNECTIONS

5.1. EXTERNAL BATTERY CONNECTION FOR LB MODELS

- The use of battery not supplied by the manufacturer is inadvisable, and before connecting it, check that it is fully compatible with the model of UPS in use.



WARNING!

There is a risk of explosion if battery modules are replaced with others of incorrect type.

- Depleted batteries are considered as toxic waste. When battery replacement becomes necessary, release all depleted batteries only to certified and licensed waste disposal companies. In accordance with local bylaws, it is absolutely forbidden to dispose of batteries together with other industrial waste or household refuse.



WARNING!

It is extremely dangerous to touch any part of the battery storage unit.





When connecting the UPS to the battery extension, use only the cable provided with the equipment.



Any wiring error that results in the polarity of the battery being inverted can cause permanent damage to the equipment.

- Connect the External Battery cable on the rear of the UPS.

6. MENU

Control panel	
Button	Description
	ON/MUTE Turn UPS on (press for 2 seconds) Up key (press and hold) Mute the alarm (press for 5 seconds) Switch to UPS self-test mode (press for 5 seconds while in AC, ECO, or converter mode)
	SELECT Setting mode (press for 5 seconds while in standby or bypass mode) Switch LCD message (press for 2 seconds) Down key (press and hold)
	OFF/ENTER Turn UPS off (press for 2 seconds) Confirm selection key (press and hold)

6.1. DISPLAY OVERVIEW

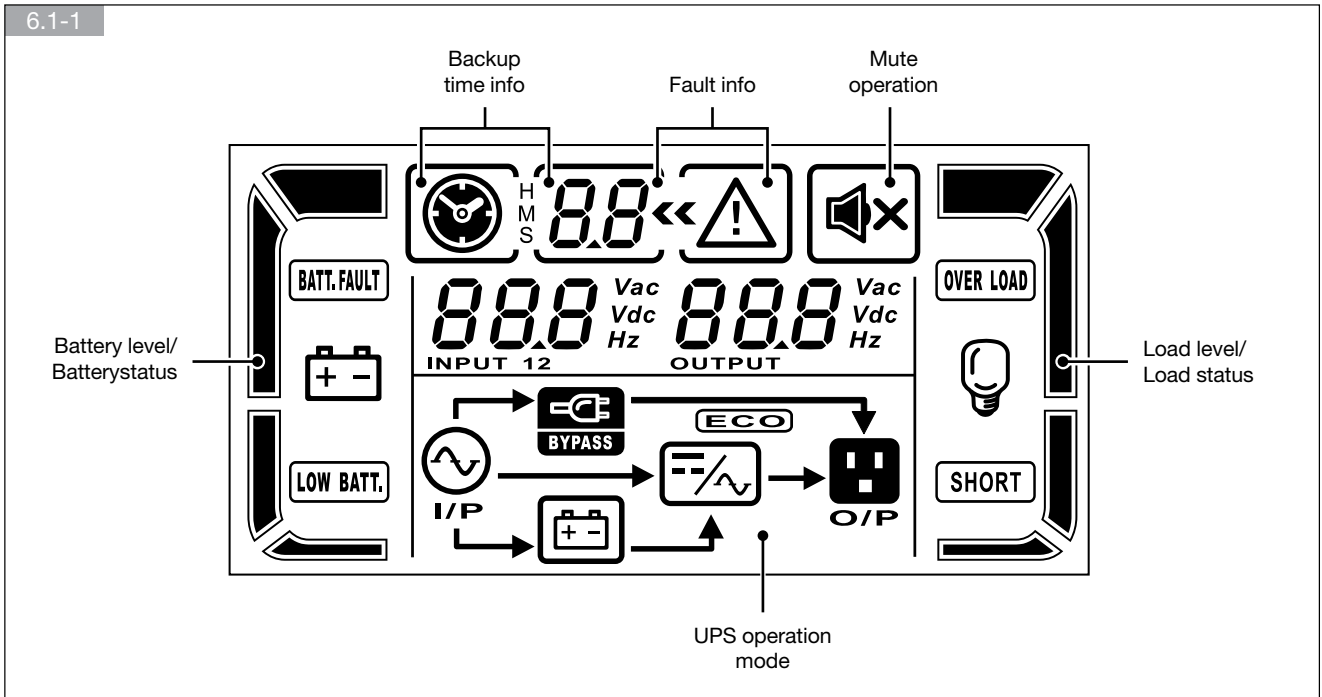

6.2. MENU FUNCTIONS DESCRIPTION

ENTER/ESC THE MENU SETTING

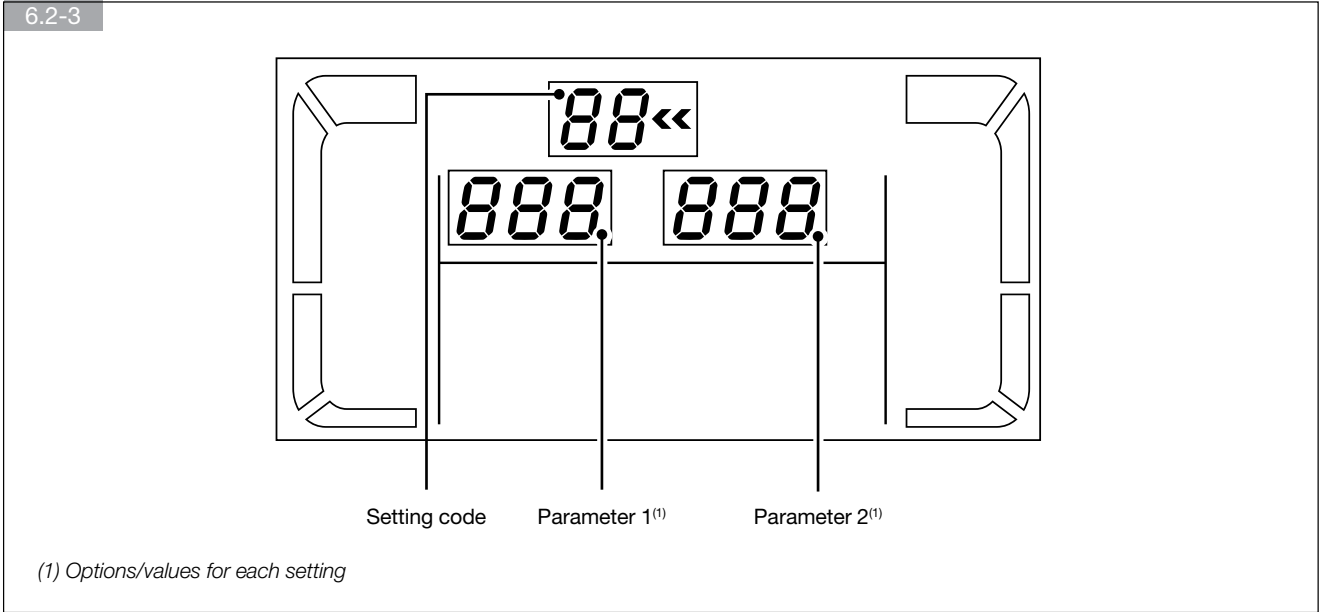
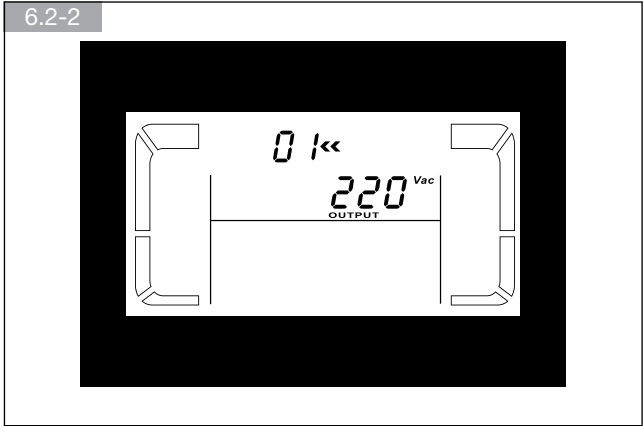
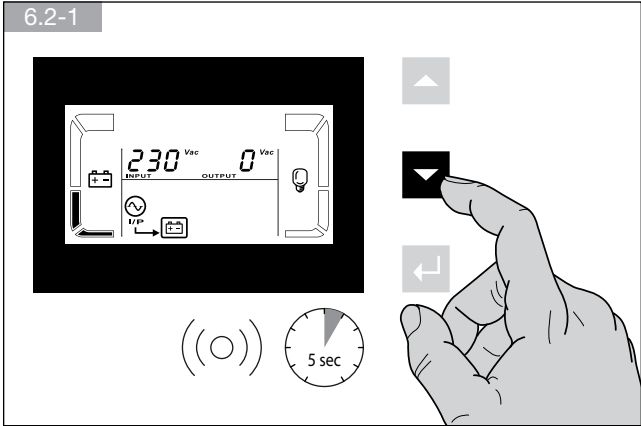

ENGLISH

Setting menu		
Setting code	Parameter 1	Parameter 2
01	Output voltage setting	Setting range: 208 to 240 Vac Default setting: 230 Vac
02	Frequency Converter enable/dis-able	CF ENA (converter mode enable) CF DIS (converter mode disable / default)
03	Output frequency setting	BAT 50 (output frequency 50 Hz) BAT 60 (output frequency 60 Hz) If converter mode is enabled: CF 50 (output frequency 50 Hz) CF 60 (output frequency 60 Hz)
04	ECO enable/disable	ENA (ECO mode enable) DIS (ECO mode disable / default)
05	ECO voltage range setting	HLS (High Loss Voltage) Setting range: +7 to +24 V (+12 V default) LLS (Low Loss Voltage) Setting range: -7 to -24 V (-12 V default)
07	Bypass voltage range setting	HLS (bypass high voltage point) Setting range: 230 to 264 Vac Default setting: 264 Vac
		LLS (bypass low voltage point) Setting range: 170 to 220 Vac Default setting: 170 Vac
08	Autonomy limitation setting	Setting range: 0 ⁽¹⁾ to 999 minutes Default setting: 999 minutes

(1) When 0 is set, backup time is only 10 seconds.

7. OPERATING PROCEDURES

7.1. SWITCHING ON

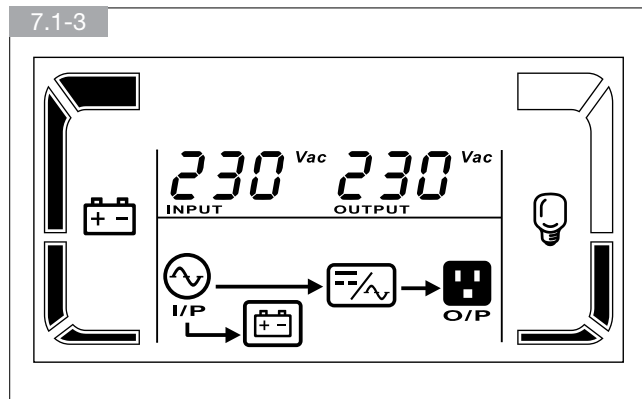
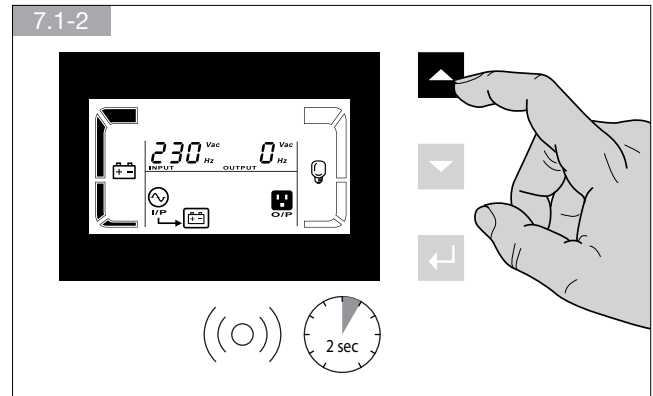
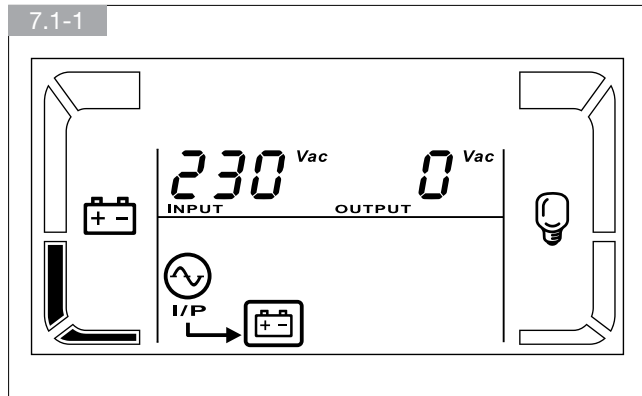

7.2. SWITCHING OFF

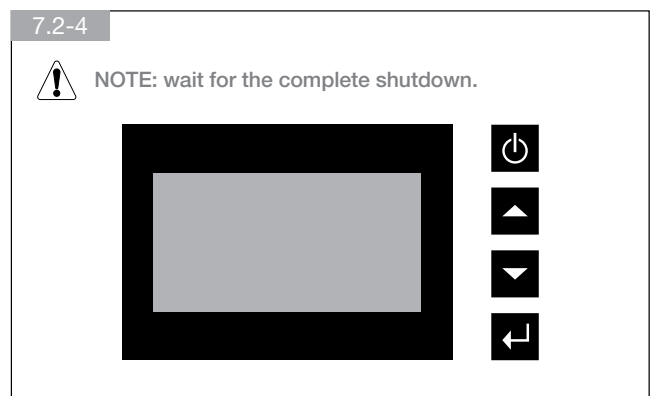
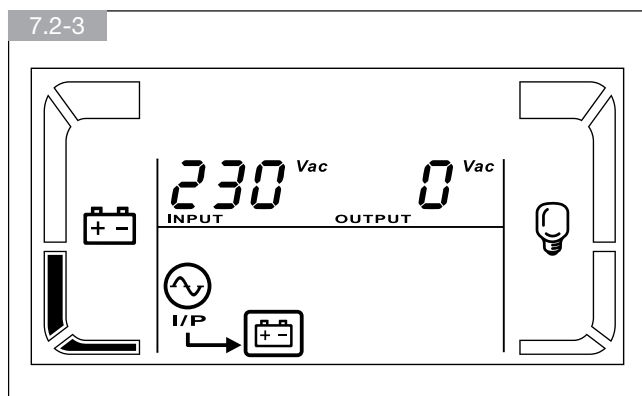
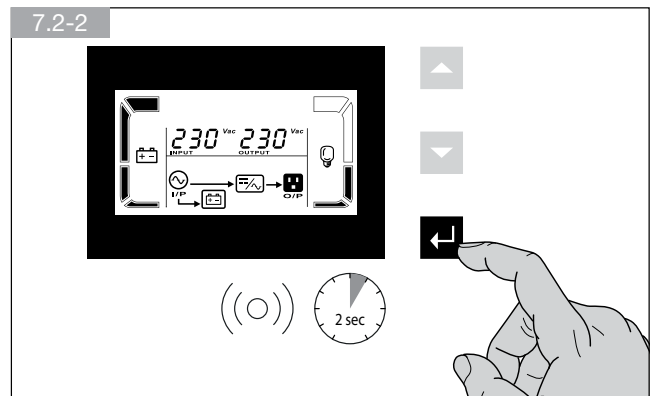
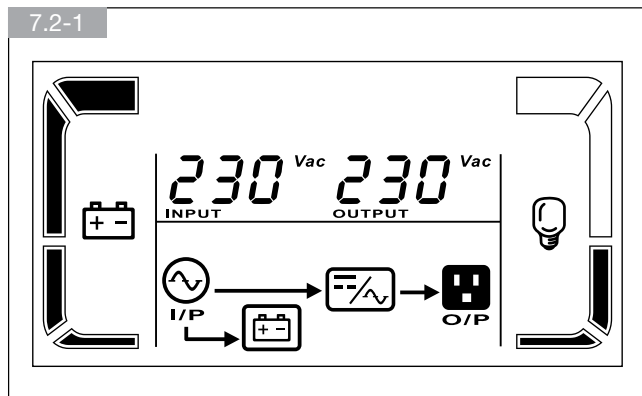

7.3. BATTERY OPERATIONS

BATTERY RECHARGING

Connect the UPS to the mains voltage for approximately 8 hours to recharge the internal batteries.

The UPS can be used even with the batteries not fully charged, though if a power cut occurs backup duration will be shorter.

BATTERY TEST

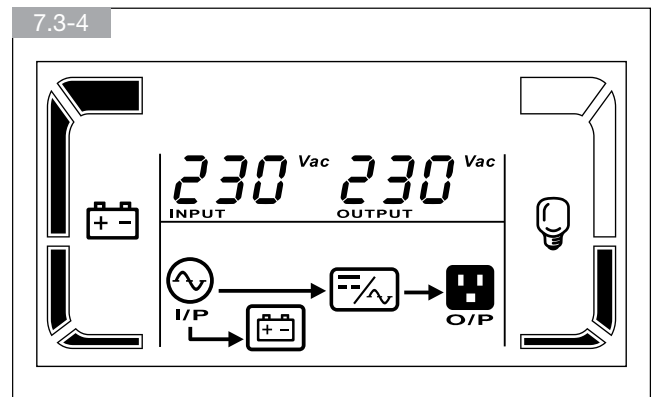
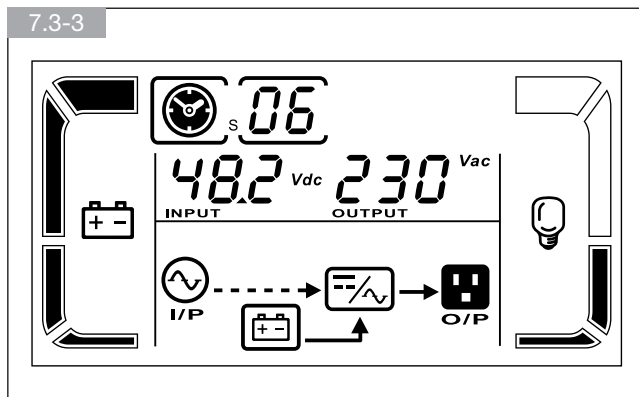
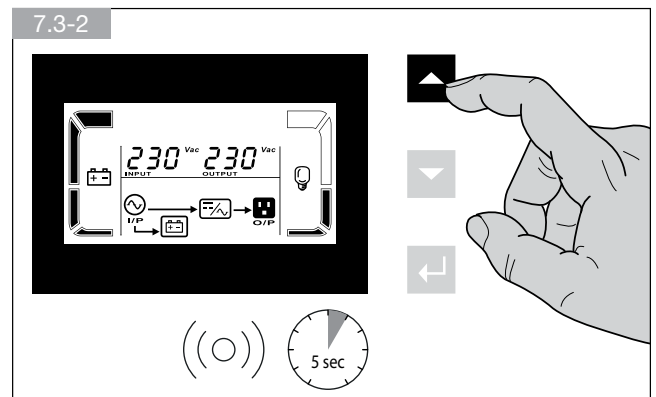
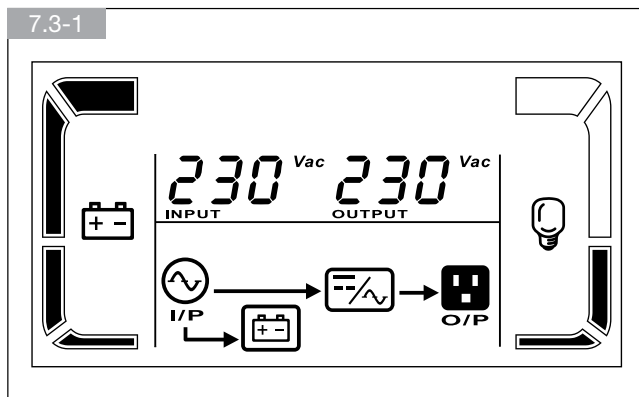

8. OPERATING MODES

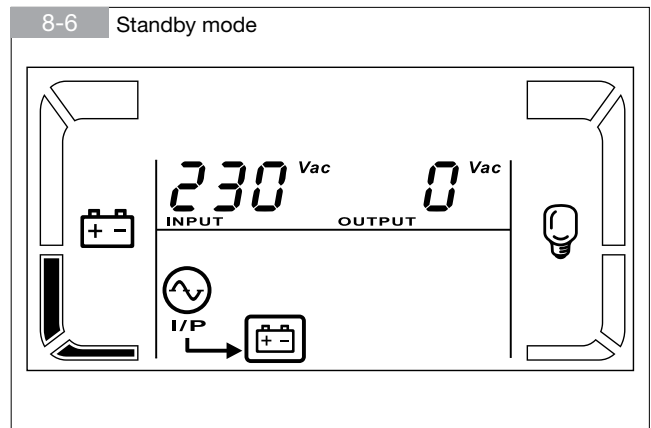
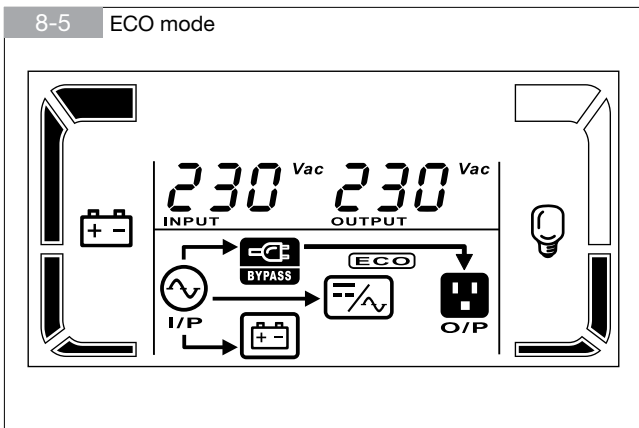
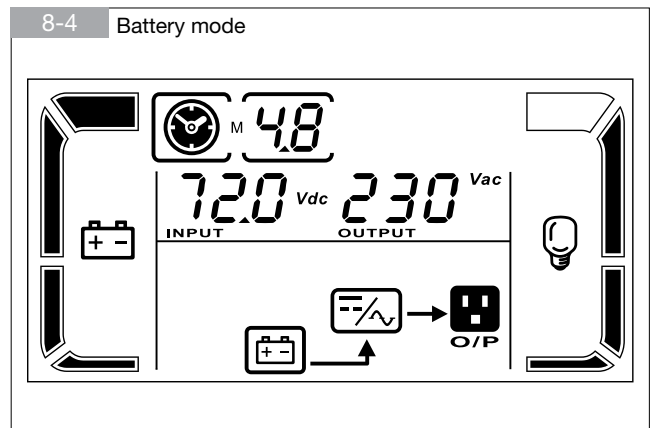
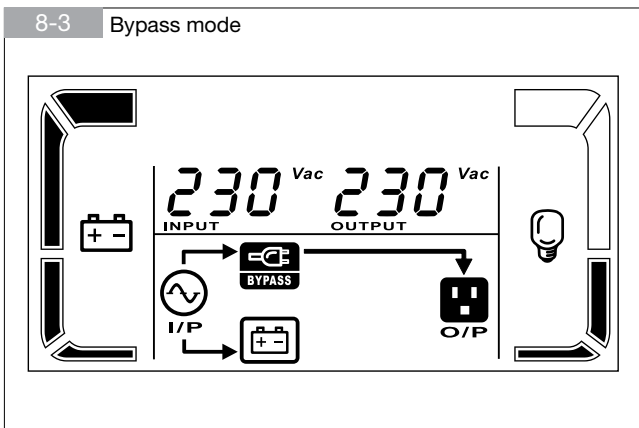
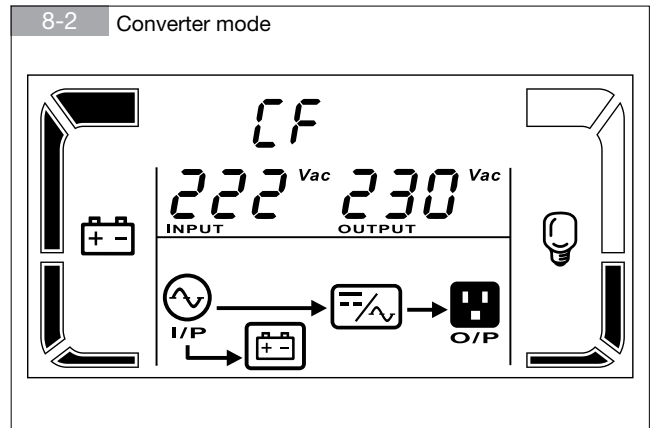
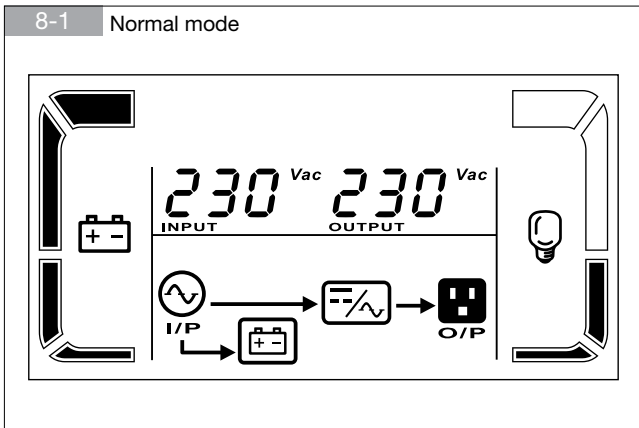

9. STANDARD FEATURES AND OPTIONAL

Communication software and accessories are available for monitoring status, for the purpose of optimising normal operation and ensuring that shutdown at the end of backup time is managed correctly. Applications allow recording of all power outages and any depletion of battery power so as to enable the activation of an automatic procedure for closing programs in an ordered sequence and shutting down the system.

USB INTERFACE

The UPS can communicate with the server directly by way of the USB interface using HID protocol, if available on the computer operating system, without the need to install any additional software. Once connected UPS recognition occurs in the same way as for any other peripheral, and the operating parameters can be managed with the OS service menu. Use the connecting cable provided.













RS232 INTERFACE

This interface is required to run **Local View** ideal UPS monitoring and shutdown point-to-point solution for Windows®, Linux® and Mac OS X® operating systems.

10. WARNING AND TROUBLESHOOTING

The following tables show the description of the LCD display string:

Code	Fault
01	Bus start fail
02	Bus over
03	Bus under
04	Bus unbalance
11	Inverter soft start fail
12	Inverter voltage high
13	Inverter voltage Low
14	Inverter output short
27	Battery voltage too high
28	Battery voltage too low
41	Over temperature
43	Overload
45	Charger fault

Warning	Icon (flashing)	Alarm
Low Battery	 LOW BATT.	Sounding every second
Overload	 OVER LOAD	Sounding twice every second
Battery is not connected	 	Sounding every second
Over Charge	 	Sounding every second
Over temperature	 TP	Sounding every second
Charger failure	 CH	Sounding every second
Battery fault	 BATT. FAULT	Sounding every 1 or 2 second
Out of bypass voltage range	 	Sounding every second
Bypass frequency unstable	 FU	Sounding every second
EEPROM error	 EE	Sounding every second

11. WARNING AND TROUBLESHOOTING











WARNING!

If problems persist or recur frequently after following the procedures indicated in this section contact the SOCOMEK After Sales Service, providing a full description of the problem.



If the UPS system does not operate correctly use the table below to try and resolve the problem.

Problem	Possible cause	Solution
No indication and alarm even though the mains is normal.	The AC input power is not connected well.	Check if input power cord firmly connected to the mains.
	The AC input is connected to the UPS output.	Plug AC input power cord to AC input correctly.
The icon  and  flashing on LCD display and alarm is sounding every second.	The external or internal battery is incorrectly connected.	Check if all batteries are connected well.
Fault code is shown as 27 and the icon  is lighting on LCD display and alarm is continuously sounding.	Battery voltage is too high or the charger is fault.	Contact your dealer.
Fault code is shown as 28 and the icon  is lighting on LCD display and alarm is continuously sounding.	Battery voltage is too low or the charger is fault.	Contact your dealer.
The icon  and  is flashing on LCD display and alarm is sounding twice every second.	UPS is overload	Remove excess loads from UPS output.
	UPS is overloaded. Devices connected to the UPS are fed directly by the electrical network via the Bypass.	Remove excess loads from UPS output.
	After repetitive overloads, the UPS is locked in the Bypass mode. Connected devices are fed directly by the mains.	Remove excess loads from UPS output first. Then shut down the UPS and restart it.
Fault code is shown as 43 and The icon  is lighting on LCD display and alarm is continuously sounding.	The UPS shut down automatically because of overload at the UPS output.	Remove excess loads from UPS output and restart it.
Fault code is shown as 14 and the icon  is lighting on LCD display and alarm is continuously sounding.	The UPS shut down automatically because short circuit occurs on the UPS output.	Check output wiring and if connected devices are in short circuit status.
Fault code is shown as 01, 02, 03, 04, 11, 12, 13, 41 and 45 on LCD display and alarm is continuously sounding.	A UPS internal fault has occurred. There are two possible results: 1. The load is still supplied, but directly from AC power via bypass. 2. The load is no longer supplied by power.	Contact your dealer
Battery backup time is shorter than nominal value	Batteries are not fully charged	Charge the batteries for at least 5 hours and then check capacity. If the problem still persists, consult your dealer.
	Batteries defect	Contact your dealer to replace the battery.

11. TECHNICAL SPECIFICATION

Models							
		B ⁽¹⁾	LB ⁽²⁾	B ⁽¹⁾	LB ⁽²⁾	B ⁽¹⁾	LB ⁽²⁾
		1	1	2	2	3	3
Nominal Power	VA/W	1000/800		2000/1600		3000/2400	
Input/Output phases		1/1		1/1		1/1	
Electrical Specifications - Input							
Mains voltage (Vin)	Vin	230 V (1ph) 160 to 300 V up to 110 V @60% load					
Input frequency	Hz	50/60 Hz					
Input power factor		≥ 0.99					
THDI		< 10 % with full load					
Electrical Specifications - Output							
Output Voltage	V	208/220/230/240 V ± 2 % The output power will be derated to 80% using 208 V as output voltage					
Frequency	Hz	50/60 Hz (47÷53 Hz / 57÷63 Hz) (in battery mode 50/60 ± 0.1 Hz)					
Overload – Normal Mode (@ 25°C)	%	Up to 130% for 1 minute					
Crest Factor		3:1					
Voltage distortion	%	< 6 % Non Linear Load; < 3 % Linear Load					
Electrical Specificationsn - Battery							
Type		Sealed lead acid maintenance free-expected life 3/5 years					
Voltage		24	36	48	96	72	96
BUT ⁽³⁾		> 8 min	-	> 8 min	-	> 8 min	-
Charger		-	up to 6 A	-	up to 6 A	-	up to 6 A
Enviroment							
Operating temperature	°C	0 to 40 °C (15 to 25 °C for maximum battery life)					
Relative humidity	%	0 to 95% without condensation					
Max. altitude	m	1000 m without derating					
Noise level at 1 m	dBA	< 55 dBA					
Standards							
Protection Level		IP20					
Mechanical Characteristics with standard batteries							
Dimensions (W x D x H)	mm	145 x 285 x 220		145 x 390 x 240		190 x 425 x 340	145 x 400 x 240
Weight	kg	10	5	17	7	28	8

1. Models with internal battery.
2. Models without battery.
3. Back-up time at 75% of rated VA load pf 0,7.

Socomec worldwide

IN EUROPE

BELGIUM

UPS / Power Control & Energy Efficiency / Solar

Tel. +32 2 340 02 30
Fax +32 2 346 28 99
info.be@socomec.com

FRANCE

UPS / Power Control & Energy Efficiency / Solar

Tel. +33 1 45 14 63 00
Fax +33 1 48 67 31 12
dcm.ups.fr@socomec.com

GERMANY

Power Control & Energy Efficiency

Tel. +49 7243 65292 0
Fax +49 7243 65292 13
info.scp.de@socomec.com

UPS

Tel. +49 621 71 68 40
Fax +49 621 71 68 444
info.ups.de@socomec.com

ITALY

Power Control & Energy Efficiency

Tel. +39 02 98 49 821
Fax +39 02 98 24 33 10
info.scp.it@socomec.com

Solar

Tel. +39 0444 598611
Fax +39 0444 598627
info.solar.it@socomec.com

UPS

Tel. +39 02 98 242 942
Fax +39 02 98 240 723
info.ups.it@socomec.com

NETHERLANDS

UPS / Power Control & Energy Efficiency / Solar

Tel. +31 30 760 0900
Fax +31 30 637 2166
info.nl@socomec.com

POLAND

Power Control & Energy Efficiency

Tel. +48 91 442 64 11
Fax +48 91 442 64 19
info.scp.pl@socomec.com

UPS

Tel. +48 22 825 73 60
Fax. +48 22 825 73 60
info.ups.pl@socomec.com

PORTUGAL

UPS / Solar

Tel. +351 261 812 599
Fax +351 261 812 570
info.ups.pt@socomec.com

ROMANIA

UPS / Power Control & Energy Efficiency / Solar

Tel. +40 21 319 36 88
Fax +40 21 319 36 89
info.ro@socomec.com

RUSSIA

UPS / Power Control & Energy Efficiency / Solar

Tel. +7 495 775 19 85
Fax +7 495 775 19 85
info.ru@socomec.com

SLOVENIA

UPS / Power Control & Energy Efficiency / Solar

Tel. +386 1 5807 860
Fax +386 1 561 11 73
info.si@socomec.com

SPAIN

UPS / Power Control & Energy Efficiency / Solar

Tel. +34 93 540 75 75
Fax +34 93 540 75 76
info.es@socomec.com

UNITED KINGDOM

Power Control & Energy Efficiency

Tel. +44 1462 440 033
Fax +44 1462 431 143
info.scp.uk@socomec.com

UPS

Tel. +44 1285 863 300
Fax +44 1285 862 304
info.ups.uk@socomec.com

TURKEY

UPS / Power Control & Energy Efficiency / Solar

Tel. +90 216 540 71 20-21-22
Fax +90 216 540 71 27
info.tr@socomec.com

IN ASIA PACIFIC

AUSTRALIA

UPS

Tel. +61 2 9325 3900
Fax +61 2 9888 9544
info.ups.au@socomec.com

CHINA

UPS / Power Control & Energy Efficiency

Tel. +86 21 52 98 95 55
Fax +86 21 62 28 34 68
info.cn@socomec.com

INDIA

Power Control & Energy Efficiency

Tel. +91 124 4027210
Fax +91 124 4562738
info.scp.in@socomec.com

UPS / Solar

Tel. +91 44 39215400
Fax +91 44 39215450 & 51
info.ups.in@socomec.com
info.solar.in@socomec.com

SINGAPORE

UPS / Power Control & Energy Efficiency

Tel. +65 6506 7600
Fax +65 64 58 7377
info.sg@socomec.com

THAILAND

UPS

Tel. +66 2 941 1644 7
Fax +66 2 941 1650
info.ups.th@socomec.com

VIETNAM

UPS

Tel. +84 8 3559 1220
Fax +84 8 3559 1221
info.ups.vn@socomec.com

IN MIDDLE EAST

UNITED ARAB EMIRATES

UPS / Power Control & Energy Efficiency / Solar

Tel. +971 4 29 98 441
Fax +971 4 29 98 449
info.ae@socomec.com

IN AMERICA

USA, CANADA & MEXICO

Power Control & Energy Efficiency

Tel. +1 617 245 0447
Fax +1 617 245 0437
info.us@socomec.com

OTHER COUNTRIES

NORTH AFRICA

Algeria / Morocco / Tunisia
info.naf@socomec.com

AFRICA

Other countries
info.africa@socomec.com

SOUTH EUROPE

Cyprus / Greece / Israel / Malta
info.se@socomec.com

SOUTH AMERICA

Tel. +34 93 540 75 75
info.es@socomec.com

MORE DETAILS

www.socomec.com/worldwide

HEAD OFFICE

SOCOMECC GROUP

S.A. SOCOMECC capital 10 816 800€
R.C.S. Strasbourg B 548 500 149
B.P. 60010 - 1, rue de Westhouse
F-67235 Benfeld Cedex - FRANCE
Tel. +33 3 88 57 41 41
Fax +33 3 88 74 08 00
info.scp.isd@socomec.com

www.socomec.com

YOUR DISTRIBUTOR



IOMITYTXXOB - GB 03 05.2015



socomec
Innovative Power Solutions